



37X1  
COMMERCIAL REFRIGERATOR  
LESS CONDENSING UNIT



COMPONENT

CASE SPECIFICATIONS:

REFRIGERATION  
LOAD: 10,500 BTU/hr  
SUCTION TEMP: 22° F  
LIQUID LINE: 3/8IN ODS  
SUCTION LINE: 5/8IN ODS

ELECTRICAL 115VAC, 60HZ, 1PH.  
EVAP. FANS: .6A  
LIGHTS: 2.4A  
TOTAL: 3.0A  
MCA: 15.0A

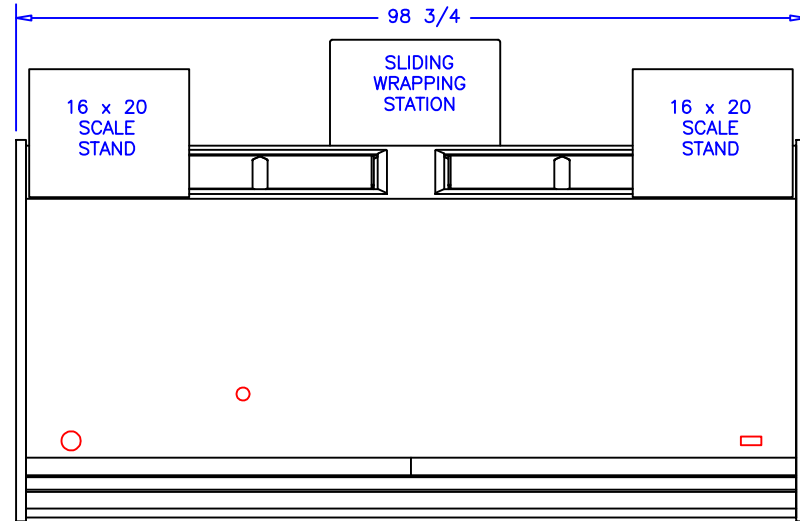

CONNECTIONS TBD DURING CASE DESIGN

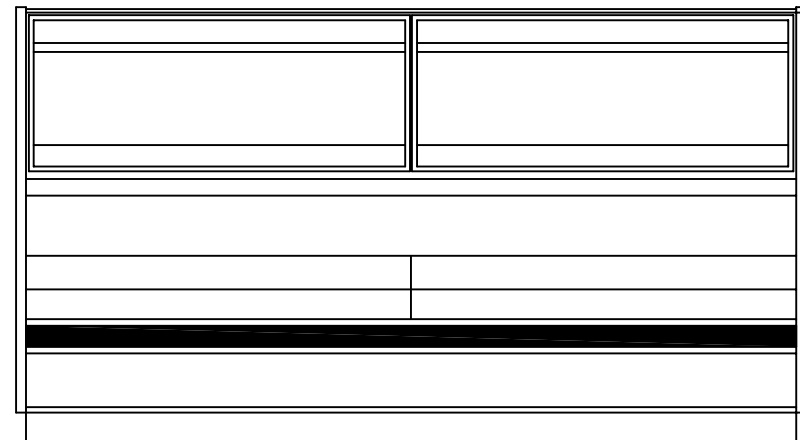
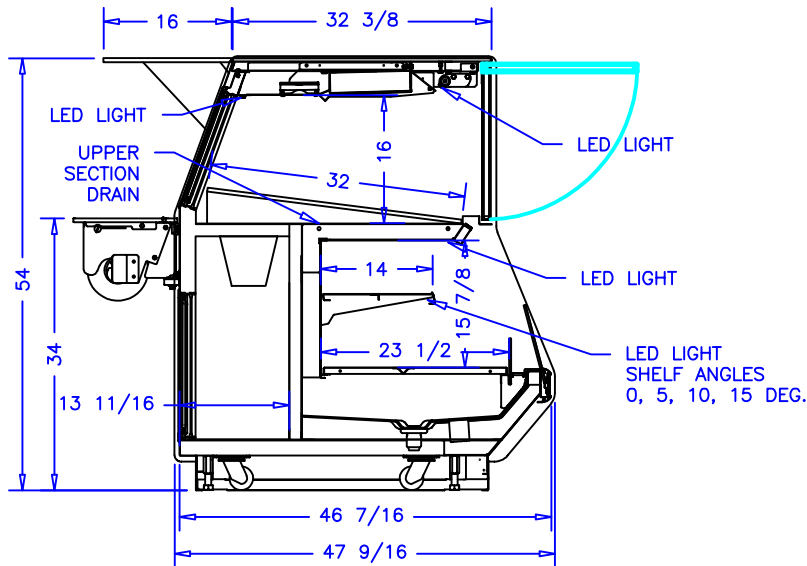

NOTES:

1. OPTIONS NOT SHOWN ON DRAWING SHOULD BE LISTED IN WRITTEN PROPOSAL AND LISTED ON PURCHASE ORDER.
2. ELEC. CONNECTION: 115V/230V, 4x4 SUPPLY BOX AS NEEDED.
3. EXPANSION VALVES: SPORLAN "Q" SERIES STANDARD UNLESS OTHERWISE SPECIFIED.
4. DEFROST CONTROL: REMOTE CASES (N/A, DIGITAL CASE CONTROLLERS AVAILABLE), OPTIONAL CONDENSING UNIT (DIGITAL CASE CONTROLLER).
5. THERMOSTATS & LIQUID LINE SOLENOID VALVES: OPTIONAL.
6. DRAIN: 1 1/2 INCH PVC.
7. SPECIFICATIONS SUBJECT TO CHANGE WITHOUT NOTICE.

AUTHORIZATION (PRINT):	DATE:			SCALE: 1:32	DRAWN BY: D HUNT
SIGNATURE:				DATE: 3-15-22	CHECKED BY:
		8' JEWEL OVER SELF SERV.			DRAWING NUMBER
		DATE	REV.	DIM: INCH	P8240
		REVISION	TOL:		