



37X1
COMMERCIAL REFRIGERATOR
LESS CONDENSING UNIT



COMPONENT

CASE SPECIFICATIONS:

REFRIGERATION
LOAD: 7,900 BTU/hr
SUCTION TEMP: 22° F
LIQUID LINE: 3/8IN ODS
SUCTION LINE: 5/8IN ODS

ELECTRICAL 115VAC, 60HZ, 1PH.
EVAP. FANS: .6A
LIGHTS: 2.4A
TOTAL: 3.0A
MCA: 15.0A

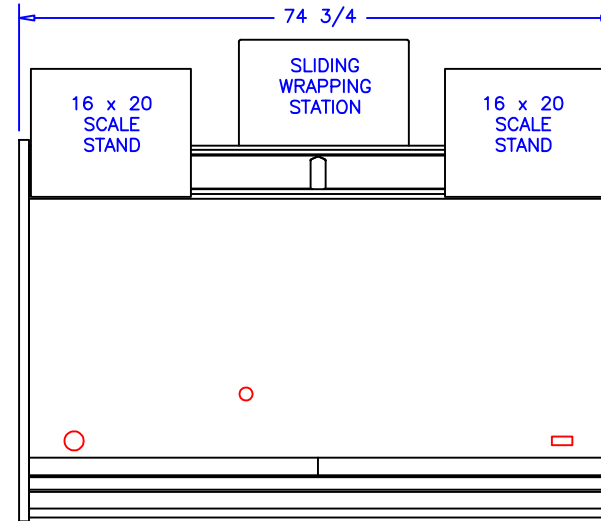

CONNECTIONS TBD DURING CASE DESIGN

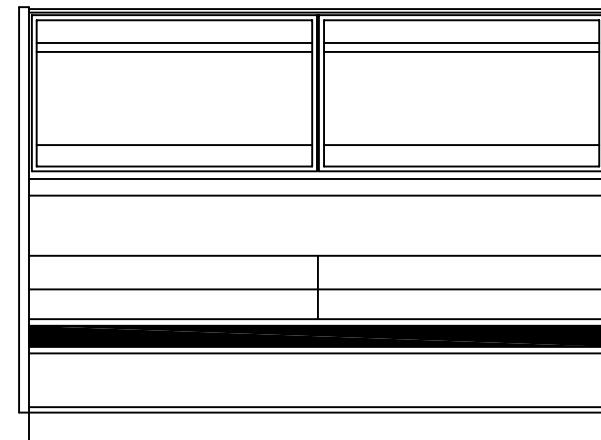
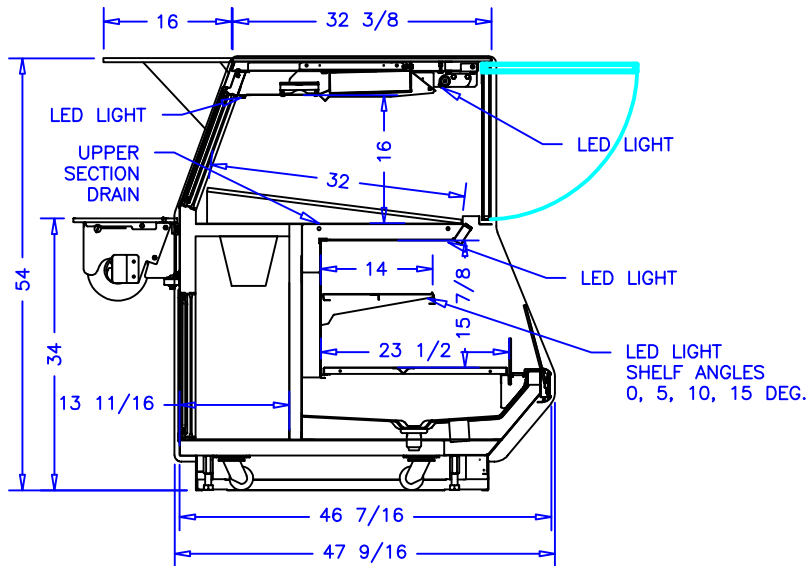

NOTES:

1. OPTIONS NOT SHOWN ON DRAWING SHOULD BE LISTED IN WRITTEN PROPOSAL AND LISTED ON PURCHASE ORDER.
2. ELEC. CONNECTION: 115V/230V, 4x4 SUPPLY BOX AS NEEDED.
3. EXPANSION VALVES: SPORLAN "Q" SERIES STANDARD UNLESS OTHERWISE SPECIFIED.
4. DEFROST CONTROL: REMOTE CASES (N/A, DIGITAL CASE CONTROLLERS AVAILABLE), OPTIONAL CONDENSING UNIT (DIGITAL CASE CONTROLLER).
5. THERMOSTATS & LIQUID LINE SOLENOID VALVES: OPTIONAL.
6. DRAIN: 1 1/2 INCH PVC.
7. SPECIFICATIONS SUBJECT TO CHANGE WITHOUT NOTICE.

AUTHORIZATION (PRINT):	DATE:			SCALE: 1:32	DRAWN BY: D HUNT
SIGNATURE:				DATE: 3-15-22	CHECKED BY:
		6' JEWEL OVER SELF SERV.			
DATE	REV.	DR:	INCH	DRAWING NUMBER	
REVISION		TOL:		P8239	