

CASE SPECIFICATIONS:

REFRIGERATION

LOAD: 7,125 BTU/hr  
 SUCTION TEMP: 22° F  
 LIQUID LINE: 3/8IN ODS  
 SUCTION LINE: 5/8IN ODS

ELECTRICAL 115VAC, 60HZ, 1PH.

EVAP. FANS: .6A  
 LIGHTS: 2.4A  
 TOTAL: 3.0A  
 MCA: 15.0A

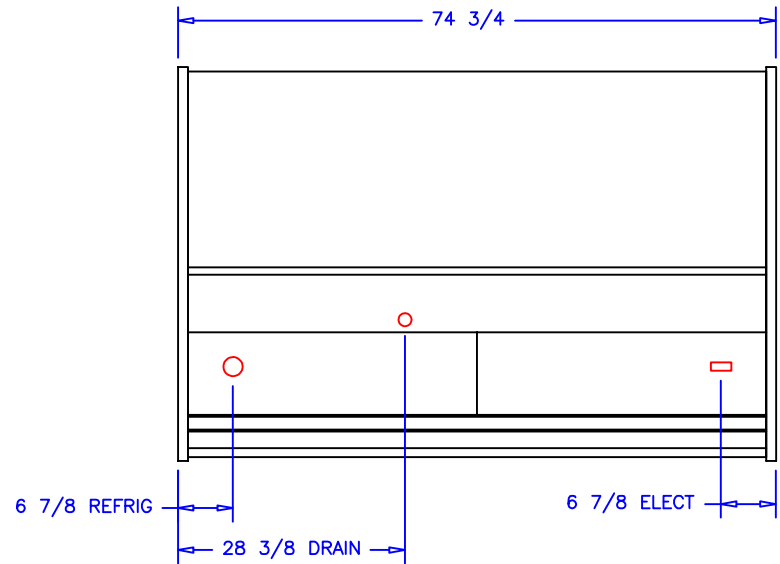
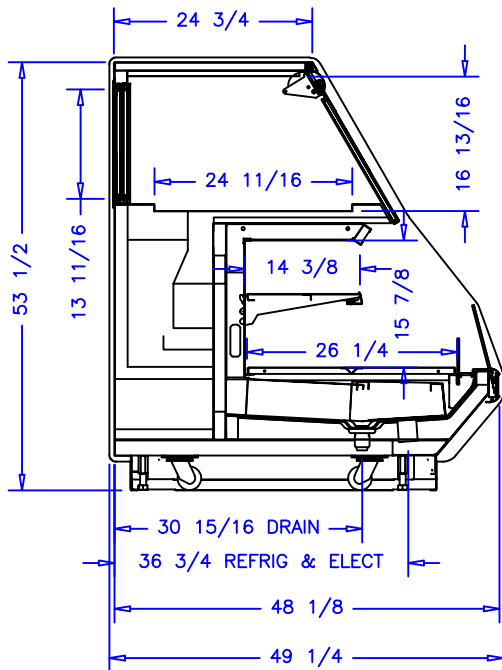

NOTES:

1. OPTIONS NOT SHOWN ON DRAWING SHOULD BE LISTED IN WRITTEN PROPOSAL AND LISTED ON PURCHASE ORDER.
2. ELEC. CONNECTION: 115V/230V, 4x4 SUPPLY BOX AS NEEDED.
3. EXPANSION VALVES: SPORLAN "Q" SERIES STANDARD UNLESS OTHERWISE SPECIFIED.
4. DEFROST CONTROL: REMOTE CASES (N/A, DIGITAL CASE CONTROLLERS AVAILABLE), OPTIONAL CONDENSING UNIT (DIGITAL CASE CONTROLLER).
5. THERMOSTATS & LIQUID LINE SOLENOID VALVES: OPTIONAL.
6. DRAIN: 1 1/2 INCH PVC.
7. SPECIFICATIONS SUBJECT TO CHANGE WITHOUT NOTICE.



AUTHORIZATION (PRINT):	DATE:					 <b>börgeren systems</b>	DRAWN BY: D HUNT
SIGNATURE:					SCALE: 1:32		CHECKED BY:
					DATE: 6-16-21		
					6' SERV OVER SELF SERV UNDER		
		DATE	REV.	DN:	INCH		DRAWING NUMBER
		REVISION		TOL:			P8130