

CASE SPECIFICATIONS:

REFRIGERATION

LOAD: 14,250 BTU/hr
 SUCTION TEMP: 22° F
 LIQUID LINE: 3/8IN ODS
 SUCTION LINE: 5/8IN ODS

ELECTRICAL 115VAC, 60HZ, 1PH.

EVAP. FANS: .9A
 LIGHTS: 3.6A
 TOTAL: 4.5A
 MCA: 15.0A

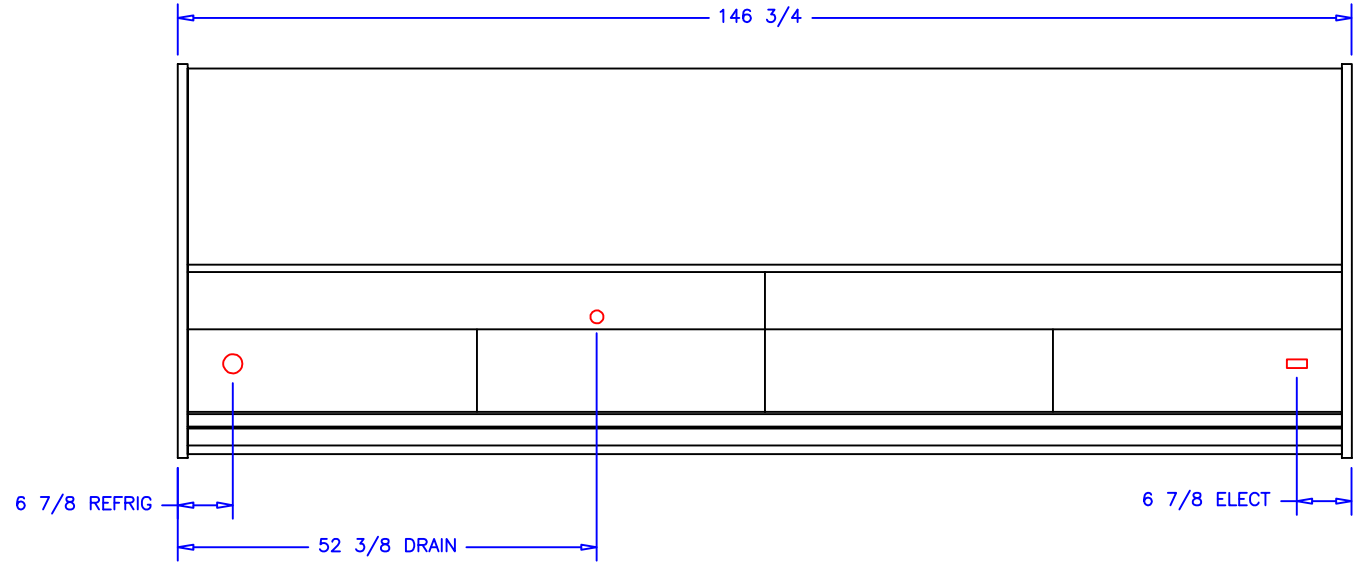
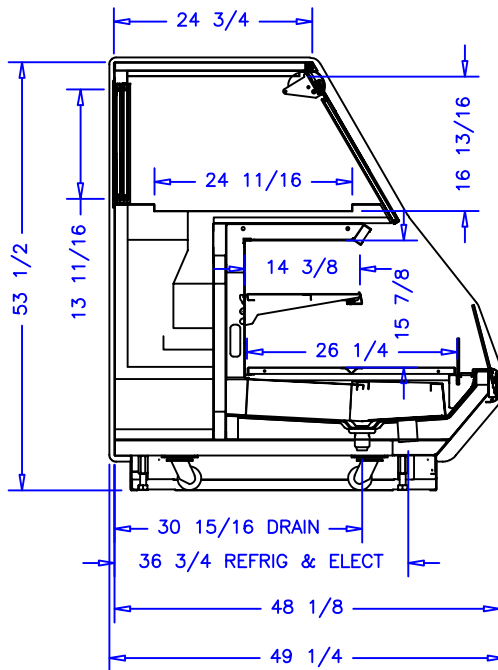

NOTES:

1. OPTIONS NOT SHOWN ON DRAWING SHOULD BE LISTED IN WRITTEN PROPOSAL AND LISTED ON PURCHASE ORDER.
2. ELEC. CONNECTION: 115V/230V, 4x4 SUPPLY BOX AS NEEDED.
3. EXPANSION VALVES: SPORLAN "Q" SERIES STANDARD UNLESS OTHERWISE SPECIFIED.
4. DEFROST CONTROL: REMOTE CASES (N/A, DIGITAL CASE CONTROLLERS AVAILABLE), OPTIONAL CONDENSING UNIT (DIGITAL CASE CONTROLLER).
5. THERMOSTATS & LIQUID LINE SOLENOID VALVES: OPTIONAL.
6. DRAIN: 1 1/2 INCH PVC.
7. SPECIFICATIONS SUBJECT TO CHANGE WITHOUT NOTICE.



AUTHORIZATION (PRINT):		DATE:		 börgeren systems	
SIGNATURE:					
				DATE: 6-16-21	CHECKED BY:
				12' SERV OVER SELF SERV UNDER	
DATE	REV.	DN:	INCH	DRAWING NUMBER	
REVISION	TOL:			P8127	