

CASE SPECIFICATIONS:

REFRIGERATION

DOORED LOAD: 1,725 BTU/hr
 OPEN LOAD: 8,300 BTU/hr
 TOTAL LOAD: 10,025 BTU/hr
 SUCTION TEMP: 25° F
 LIQUID LINE: 3/8IN ODS
 SUCTION LINE: 5/8IN ODS

ELECTRICAL 115VAC, 60HZ, 1PH.

EVAP. FANS: 1.2A
 LIGHTS: 3.6A
 CONDENSATE PUMP: 1.0A
 TOTAL: 5.2A
 MCA: 15.0A

ELECTRICAL 230VAC, 60HZ, 1PH.

EVAP. PAN: 6.5A
 1 1/4HP COND. UNIT: 9.2A
 TOTAL: 15.7A
 MCA: 18.7A

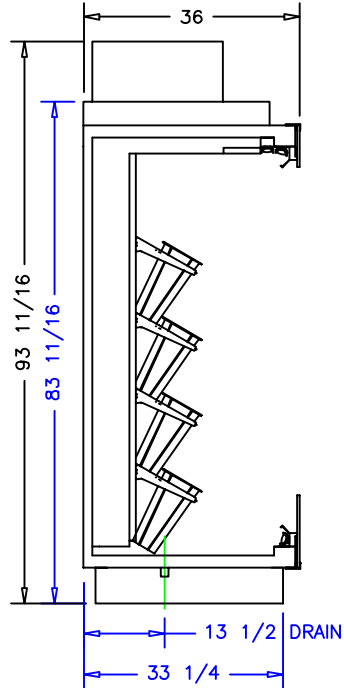
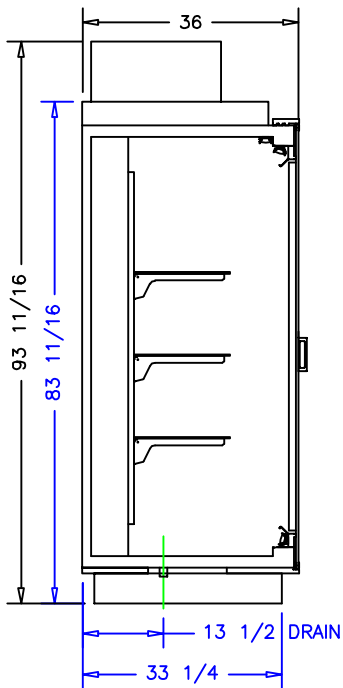
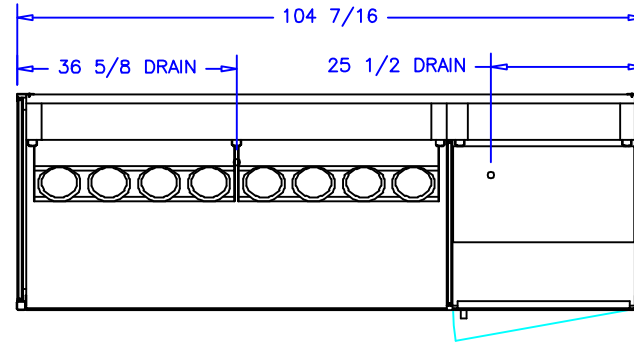

NOTES:

1. OPTIONS NOT SHOWN ON DRAWING SHOULD BE LISTED IN WRITTEN PROPOSAL AND LISTED ON PURCHASE ORDER.
2. ELEC. CONNECTION: 115V/230V, 4x4 SUPPLY BOX AS NEEDED.
3. EXPANSION VALVES: SPORLAN "Q" SERIES STANDARD UNLESS OTHERWISE SPECIFIED.
4. DEFROST CONTROL: REMOTE CASES (N/A, DIGITAL CASE CONTROLLERS AVAILABLE), OPTIONAL CONDENSING UNIT (DIGITAL CASE CONTROLLER).
5. THERMOSTATS & LIQUID LINE SOLENOID VALVES: OPTIONAL.
6. DRAIN: 1 1/2 INCH PVC.
7. SPECIFICATIONS SUBJECT TO CHANGE WITHOUT NOTICE.



AUTHORIZATION (PRINT):	DATE:			 börigen systems		
SIGNATURE:		SCALE: 1:32	DRAWN BY: D HUNT			
		DATE: 10-16-18	CHECKED BY:	1DR 6FT COMBO LEFT		
		DATE	REV.	DWG.	INCH	DRAWING NUMBER
		REVISION		TOL:		P7647