

CASE SPECIFICATIONS:

REFRIGERATION:
 LOAD: 3,500 BTU/hr
 COIL TEMP: 25°F
 SUCTION STUB: 5/8IN ODS
 LIQUID STUB: 3/8IN ODS

ELECTRICAL 115V, 60HZ, 1PH
 EVAP. FANS: 0.30A
 LED LIGHT: 2.4A
 CONDENSATE PUMP: 1.0A
 CONDENSATE PAN: 5.2A
 1/2 HP COND. UNIT: 9.2A
 TOTAL: 18.1A
 MCA: 20.9A

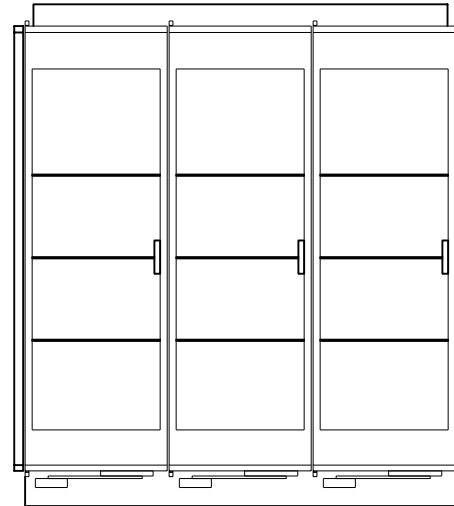
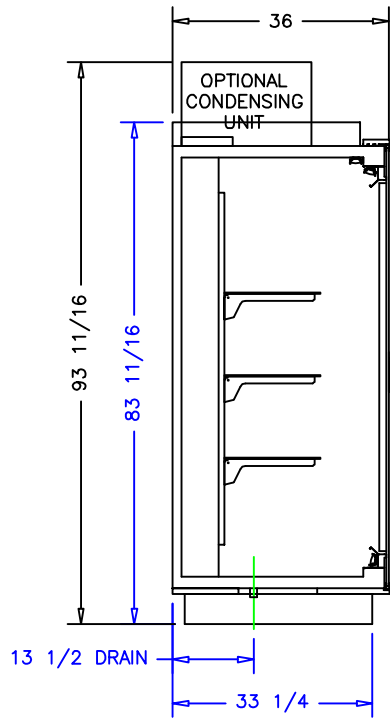
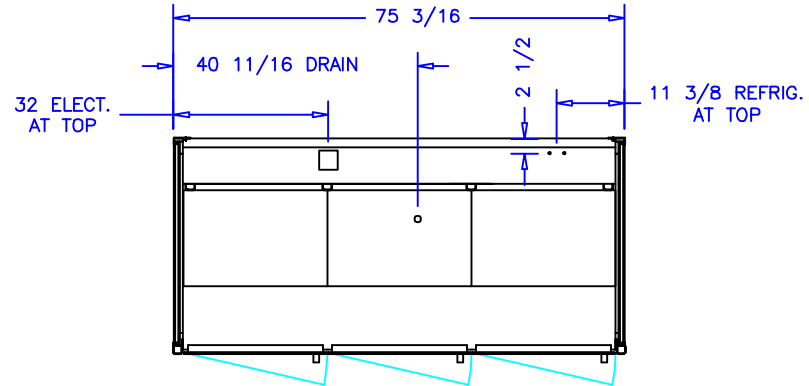

NOTES:

1. OPTIONS NOT SHOWN ON DRAWING SHOULD BE LISTED IN WRITTEN PROPOSAL AND LISTED ON PURCHASE ORDER.
2. ELEC. CONNECTION: 115V/230V, 4x4 SUPPLY BOX AS NEEDED.
3. EXPANSION VALVES: SPORLAN "Q" SERIES STANDARD UNLESS OTHERWISE SPECIFIED.
4. DEFROST CONTROL: REMOTE CASES (N/A, DIGITAL CASE CONTROLLERS AVAILABLE), OPTIONAL CONDENSING UNIT (DIGITAL CASE CONTROLLER).
5. THERMOSTATS & LIQUID LINE SOLENOID VALVES: OPTIONAL.
6. DRAIN: 1 1/2 INCH PVC.
7. SPECIFICATIONS SUBJECT TO CHANGE WITHOUT NOTICE.



| | | | | | | | | | |
|------------------------|--|-------|--|---|--|---------------|--|------------------|--|
| AUTHORIZATION (PRINT): | | DATE: | |  börgeren systems | | SCALE: 1:32 | | DRAWN BY: D HUNT | |
| | | | | | | DATE: 10-2-18 | | CHECKED BY: | |
| | | | | 3 DOOR | | | | | |
| DATE | | REV. | | DIM: | | INCH | | DRAWING NUMBER | |
| | | | | | | PQ10 | | P7632 | |