

FRONT HALF CASE SPECIFICATIONS:      BACK HALF CASE SPECIFICATIONS:

REFRIGERATION  
 LOAD: 13,000 BTU/hr  
 SUCTION TEMP: 22° F  
 LIQUID LINE: 3/8IN ODS  
 SUCTION LINE: 5/8IN ODS

REFRIGERATION  
 LOAD: 13,000 BTU/hr  
 SUCTION TEMP: 22° F  
 LIQUID LINE: 3/8IN ODS  
 SUCTION LINE: 5/8IN ODS

ELECTRICAL 115VAC, 60HZ, 1PH.  
 EVAP. FANS: 1.2A  
 LIGHT BALLAST: 2.4A  
 TOTAL: 3.6A  
 MCA: 15.0A

ELECTRICAL 115VAC, 60HZ, 1PH.  
 EVAP. FANS: 1.2A  
 LIGHT BALLAST: 2.4A  
 TOTAL: 3.6A  
 MCA: 15.0A

ELECTRICAL 230VAC, 60HZ, 1PH.  
 EVAP. PAN: 7.2A  
 1 1/2HP COND. UNIT: 10.9A  
 TOTAL: 24.8A  
 MCA: 35.0A

ELECTRICAL 230VAC, 60HZ, 1PH.  
 EVAP. PAN: 7.2A  
 1 1/2HP COND. UNIT: 10.9A  
 TOTAL: 24.8A  
 MCA: 35.0A

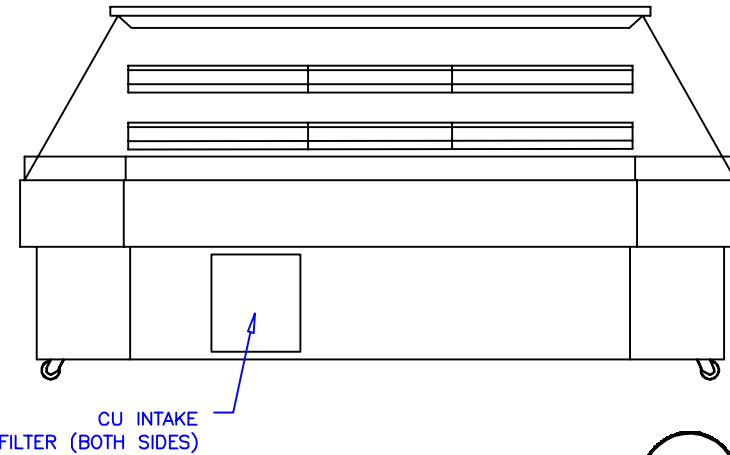
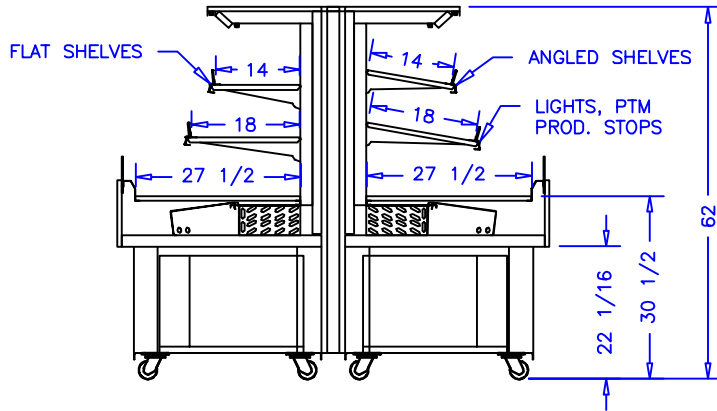
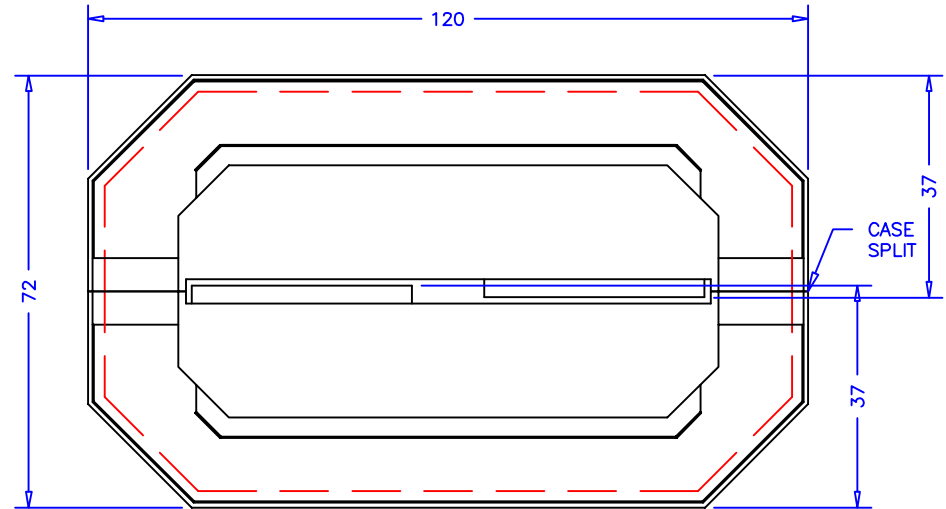

NOTES:

1. OPTIONS NOT SHOWN ON DRAWING SHOULD BE LISTED IN WRITTEN PROPOSAL AND LISTED ON PURCHASE ORDER.
2. ELEC. CONNECTION: 115V/230V, 4x4 SUPPLY BOX AS NEEDED.
3. EXPANSION VALVES: SPORLAN "Q" SERIES STANDARD UNLESS OTHERWISE SPECIFIED.
4. DEFROST CONTROL: REMOTE CASES (N/A, DIGITAL CASE CONTROLLERS AVAILABLE), OPTIONAL CONDENSING UNIT (DIGITAL CASE CONTROLLER).
5. THERMOSTATS & LIQUID LINE SOLENOID VALVES: OPTIONAL.
6. DRAIN: 1 1/2 INCH PVC.
7. SPECIFICATIONS SUBJECT TO CHANGE WITHOUT NOTICE.



AUTHORIZATION (PRINT):		DATE:		 <b>börgeren systems</b>		SCALE: 1:32		DRAWN BY: D HUNT	
SIGNATURE:						DATE: 12-15-17		CHECKED BY:	
				10FT MULTI DECK ISLAND OCU					
DATE		REV.		DIM:		INCH		DRAWING NUMBER	
REVISION		TOL:						P7457	