

CASE SPECIFICATIONS:

REFRIGERATION  
 LOAD: 3,570 BTU/hr  
 SUCTION TEMP: 22° F  
 LIQUID LINE: 3/8IN ODS  
 SUCTION LINE: 5/8IN ODS

ELECTRICAL 115VAC, 60HZ, 1PH.  
 EVAP. FANS: .30A  
 LED LIGHT: 2.4A  
 CONDENSATE PUMP: 1.0A  
 EVAP. PAN: 3.0A  
 1/2HP COND. UNIT: 9.2A  
 TOTAL: 15.9A  
 MCA: 20.0A

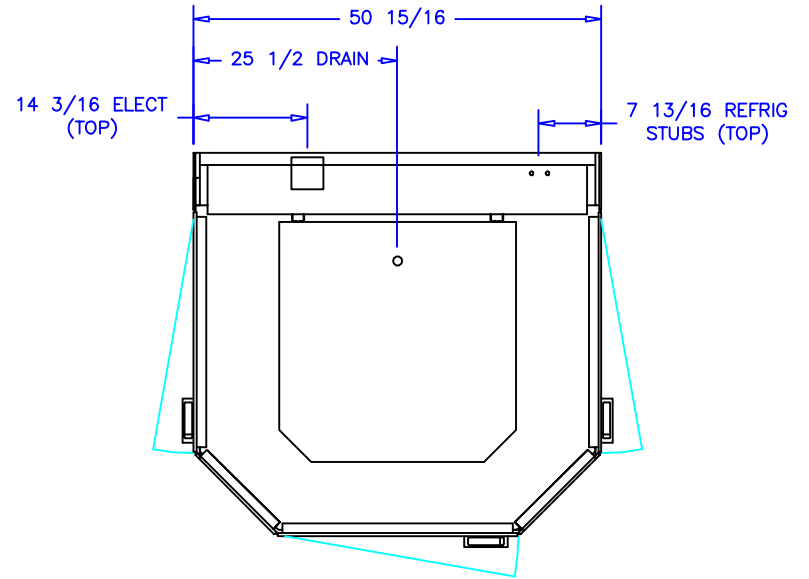

NOTES:

1. OPTIONS NOT SHOWN ON DRAWING SHOULD BE LISTED IN WRITTEN PROPOSAL AND LISTED ON PURCHASE ORDER.
2. ELEC. CONNECTION: 115V/230V, 4x4 SUPPLY BOX AS NEEDED.
3. EXPANSION VALVES: SPORLAN "Q" SERIES STANDARD UNLESS OTHERWISE SPECIFIED.
4. DEFROST CONTROL: REMOTE CASES (N/A, DIGITAL CASE CONTROLLERS AVAILABLE), OPTIONAL CONDENSING UNIT (DIGITAL CASE CONTROLLER).
5. THERMOSTATS & LIQUID LINE SOLENOID VALVES: OPTIONAL.
6. DRAIN: 1 1/2 INCH PVC.
7. SPECIFICATIONS SUBJECT TO CHANGE WITHOUT NOTICE.



AUTHORIZATION (PRINT):	DATE:	 <b>börgeren systems</b>	
SIGNATURE:			
		DATE: 10-23-17	CHECKED BY:
3DR 2BAY END CAP			
DATE	REV.	DWG. INCH	DRAWING NUMBER
REVISION	TOL:		P7420