

CASE SPECIFICATIONS:

REFRIGERATION:

LOAD: 4,025 BTU/hr  
 COIL TEMP: 25°F  
 SUCTION STUB: 5/8IN ODS  
 LIQUID STUB: 3/8IN ODS

ELECTRICAL 115V, 60HZ, 1PH  
 EVAP. FANS: 0.30A  
 LED LIGHT: 2.4A  
 CONDENSATE PUMP: 1.0A  
 CONDENSATE PAN: 5.2A  
 TOTAL: 8.9A  
 MCA: 15.0A

ELECTRICAL 208/230V, 60HZ, 1PH  
 3/4 HP COND. UNIT: 6.8A  
 TOTAL: 6.8A  
 MCA: 9.6A

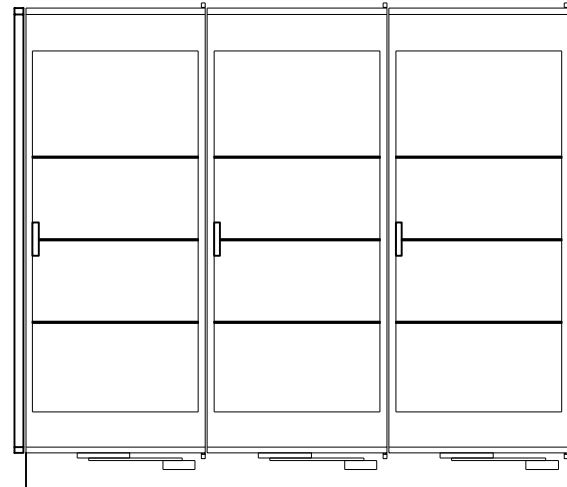
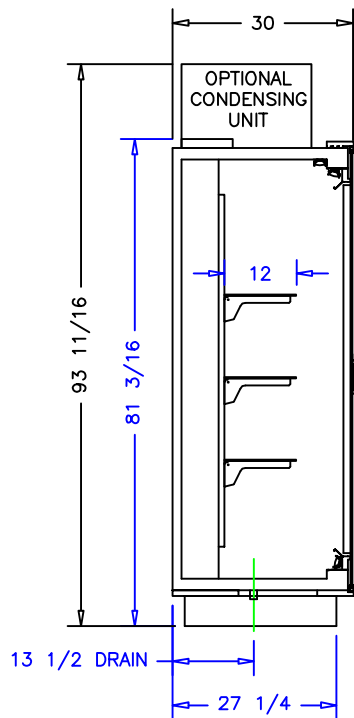
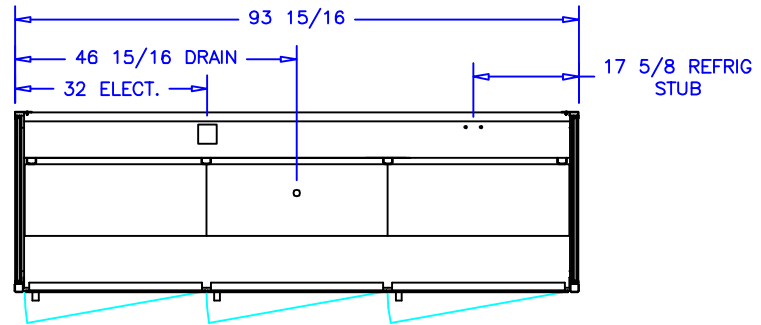

NOTES:

1. OPTIONS NOT SHOWN ON DRAWING SHOULD BE LISTED IN WRITTEN PROPOSAL AND LISTED ON PURCHASE ORDER.
2. ELEC. CONNECTION: 115V/230V, 4x4 SUPPLY BOX AS NEEDED.
3. EXPANSION VALVES: SPORLAN "Q" SERIES STANDARD UNLESS OTHERWISE SPECIFIED.
4. DEFROST CONTROL: REMOTE CASES (N/A, DIGITAL CASE CONTROLLERS AVAILABLE), OPTIONAL CONDENSING UNIT (DIGITAL CASE CONTROLLER).
5. THERMOSTATS & LIQUID LINE SOLENOID VALVES: OPTIONAL.
6. DRAIN: 1 1/2 INCH PVC.
7. SPECIFICATIONS SUBJECT TO CHANGE WITHOUT NOTICE.



AUTHORIZATION (PRINT):		DATE:		 <b>börgeren systems</b>		SCALE: 1:32		DRAWN BY: D HUNT	
						DATE: 12-9-16		CHECKED BY:	
				3 DOOR					
DATE		REV.		DIM:		INCH		DRAWING NUMBER	
						PQ10		P7230	