

CASE SPECIFICATIONS:

REFRIGERATION:

LOAD: 2,530 BTU/hr  
 COIL TEMP: 30°F  
 SUCTION STUB: 5/8IN ODS  
 LIQUID STUB: 3/8IN ODS

ELECTRICAL 115V, 60HZ, 1PH

EVAP. FANS: 0.3A  
 LIGHTS: 2.4A  
 CONDENSATE PUMP: 1.0A  
 CONDENSATE PAN: 5.2A  
 1/2 HP COND. UNIT: 9.2A  
 TOTAL: 17.1A  
 MCA: 25.0A

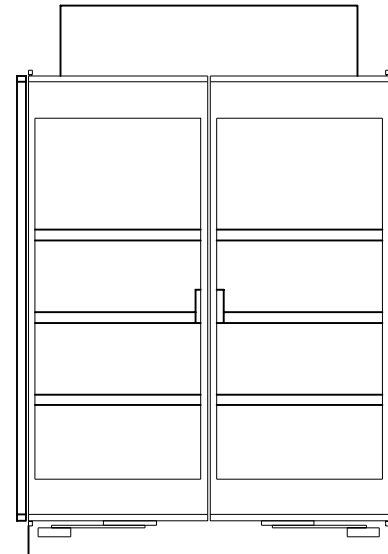
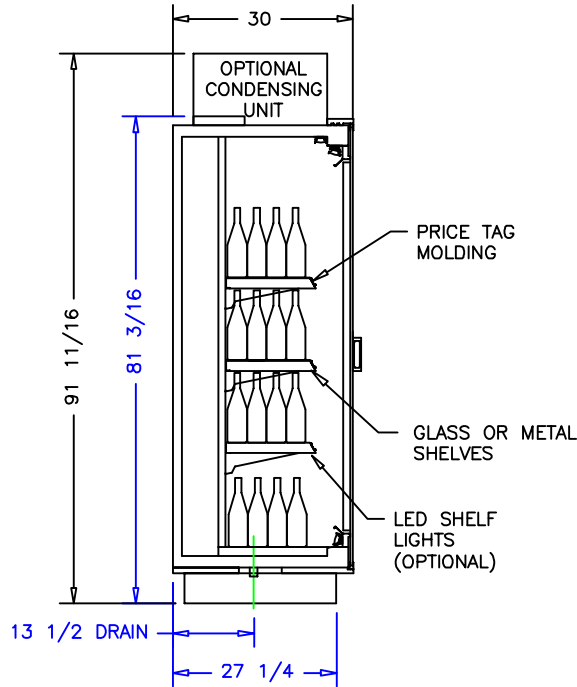
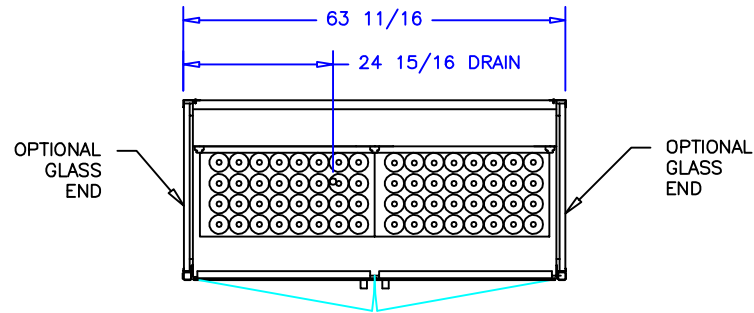

THIS EQUIPMENT IS INTENDED FOR THE STORAGE OF NON-POTENTIALLY-HAZARDOUS BOTTLED OR CANNED PRODUCTS ONLY



NOTES:

1. OPTIONS NOT SHOWN ON DRAWING SHOULD BE LISTED IN WRITTEN PROPOSAL AND LISTED ON PURCHASE ORDER.
2. ELEC. CONNECTION: 115V/230V, 4x4 SUPPLY BOX AS NEEDED.
3. EXPANSION VALVES: SPORLAN "Q" SERIES STANDARD UNLESS OTHERWISE SPECIFIED.
4. DEFROST CONTROL: REMOTE CASES (N/A, DIGITAL CASE CONTROLLERS AVAILABLE), OPTIONAL CONDENSING UNIT (DIGITAL CASE CONTROLLER).
5. THERMOSTATS & LIQUID LINE SOLENOID VALVES: OPTIONAL.
6. DRAIN: 1 1/2 INCH PVC.
7. SPECIFICATIONS SUBJECT TO CHANGE WITHOUT NOTICE.

|                        |  |       |  |   |  |               |  |                  |  |
|------------------------|--|-------|--|---|--|---------------|--|------------------|--|
| AUTHORIZATION (PRINT): |  | DATE: |  |  <b>börger systems</b> |  | SCALE: 1:32   |  | DRAWN BY: D HUNT |  |
|                        |  |       |  |   |  | DATE: 2-23-16 |  | CHECKED BY:      |  |
|                        |  |       |  | 2-8-18 DRH  |  | 2DR WINE      |  |                  |  |
| DATE                   |  | REV.  |  | DIM.  |  | INCH          |  | DRAWING NUMBER   |  |
| REVISION               |  | TOL:  |  |   |  |               |  | P7041            |  |