

CASE SPECIFICATIONS:

REFRIGERATION  
 LOAD: 2,800 BTU/hr  
 COIL TEMP: 25° F  
 LIQUID STUB: 3/8IN ODS  
 SUCTION STUB: 3/8IN ODS

ELECTRICAL 115VAC, 60HZ, 1PH.  
 EVAP. FANS: .30A  
 LIGHTS: 1.2A  
 1/3HP COND. UNIT: 6.0A  
 TOTAL: 7.5A  
 MCA: 15.0A

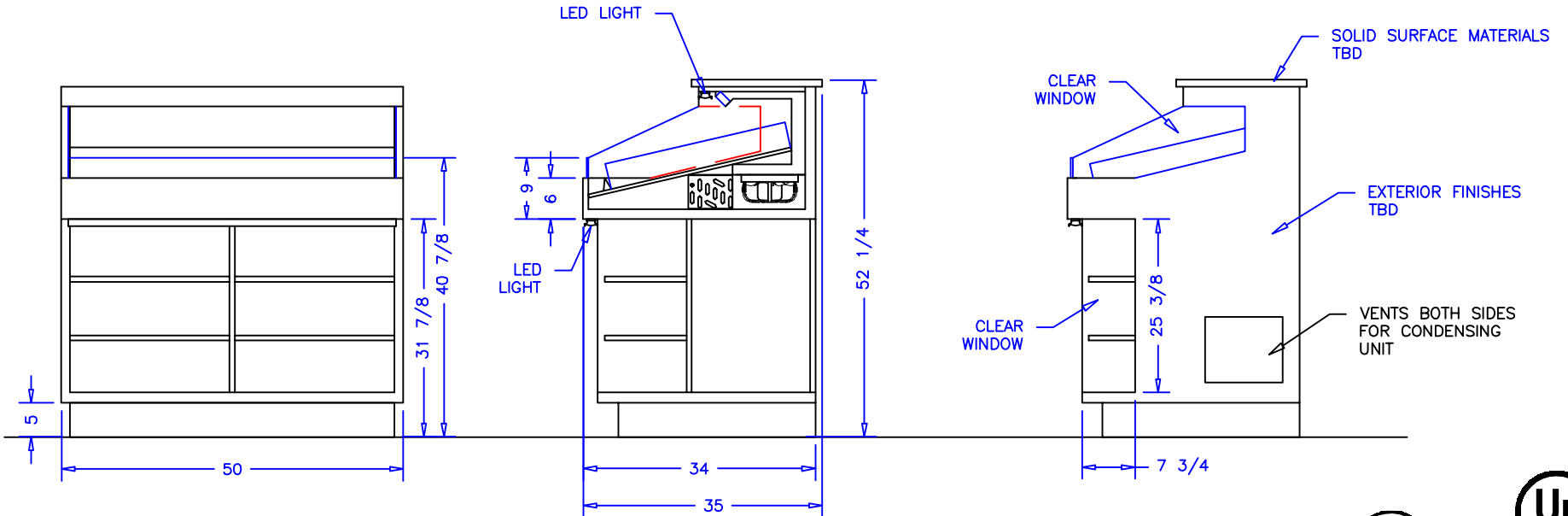

**NOTES:**

1. OPTIONS NOT SHOWN ON DRAWING SHOULD BE LISTED IN WRITTEN PROPOSAL AND LISTED ON PURCHASE ORDER.
2. ELEC. CONNECTION: 115V/230V, 4x4 SUPPLY BOX AS NEEDED.
3. EXPANSION VALVES: SPORLAN "Q" SERIES STANDARD UNLESS OTHERWISE SPECIFIED.
4. DEFROST CONTROL: REMOTE CASES (N/A, DIGITAL CASE CONTROLLERS AVAILABLE), OPTIONAL CONDENSING UNIT (DIGITAL CASE CONTROLLER).
5. THERMOSTATS & LIQUID LINE SOLENOID VALVES: OPTIONAL.
6. SPECIFICATIONS SUBJECT TO CHANGE WITHOUT NOTICE.



AUTHORIZATION (PRINT):	DATE:	 <b>börgeren systems</b>		SCALE: 1:24	DRAWN BY: D HUNT
SIGNATURE:				DATE: 10-10-17	CHECKED BY:
		4FT SINGLE DECK WITH DRY DISP.			DRAWING NUMBER
DATE	REV.	DWG.	INCH	P7415	
REVISION	TOL:				