

(A) LEFT OPEN CASE SPECIFICATIONS:

REFRIGERATION
LOAD: 8,120 BTU/hr
SUCTION TEMP: 25° F

ELECTRICAL 115VAC, 60HZ, 1PH.
EVAP. FANS: 1.2A
LIGHTS: 3.6A
TOTAL: 4.8A
MCA: 15.0A

ELECTRICAL 230VAC, 60HZ, 1PH.
1HP COND. UNIT: 9.2A
MCA: 14.9A

(C) RIGHT OPEN CASE SPECIFICATIONS:

REFRIGERATION
LOAD: 8,120 BTU/hr
SUCTION TEMP: 25° F

ELECTRICAL 115VAC, 60HZ, 1PH.
EVAP. FANS: 1.2A
LIGHTS: 3.6A
TOTAL: 4.8A
MCA: 15.0A

ELECTRICAL 230VAC, 60HZ, 1PH.
1HP COND. UNIT: 9.2A
MCA: 14.9A

(B) CASE SPECIFICATIONS:

TOP AREA: 55.7 SQR FT

REFRIGERATION LOAD: 8,800 BTU/hr
COIL: CTA 38-88
SUCTION TEMP: 25° F

ELECTRICAL 115VAC, 60HZ, 1PH.
EVAP. FANS: 3.3A
MERCH. LIGHTS: 4.8A
STORAGE LIGHTS: 0.8A
TOTAL: 8.9A

ELECTRICAL 230VAC, 60HZ, 1PH.
1HP COND. UNIT: 9.2A
MCA: 14.9A

WALK-IN COOLER:
VENT ABOVE THE
SERVICE DOOR.

DISPLAY INFORMATION:
TEMPERED GLASS SHELVES
ARE HEIGHT ADJUSTABLE.

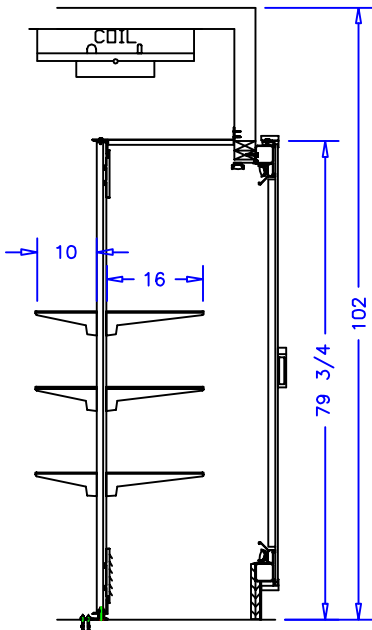
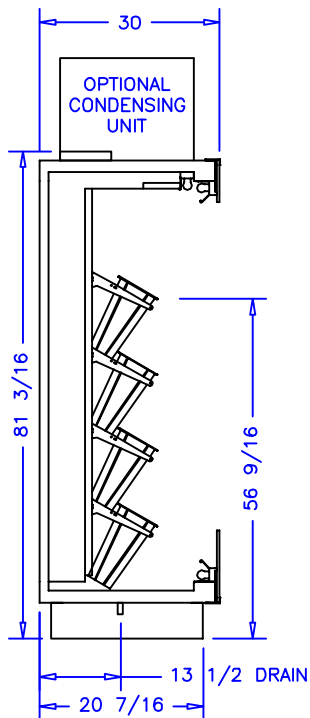
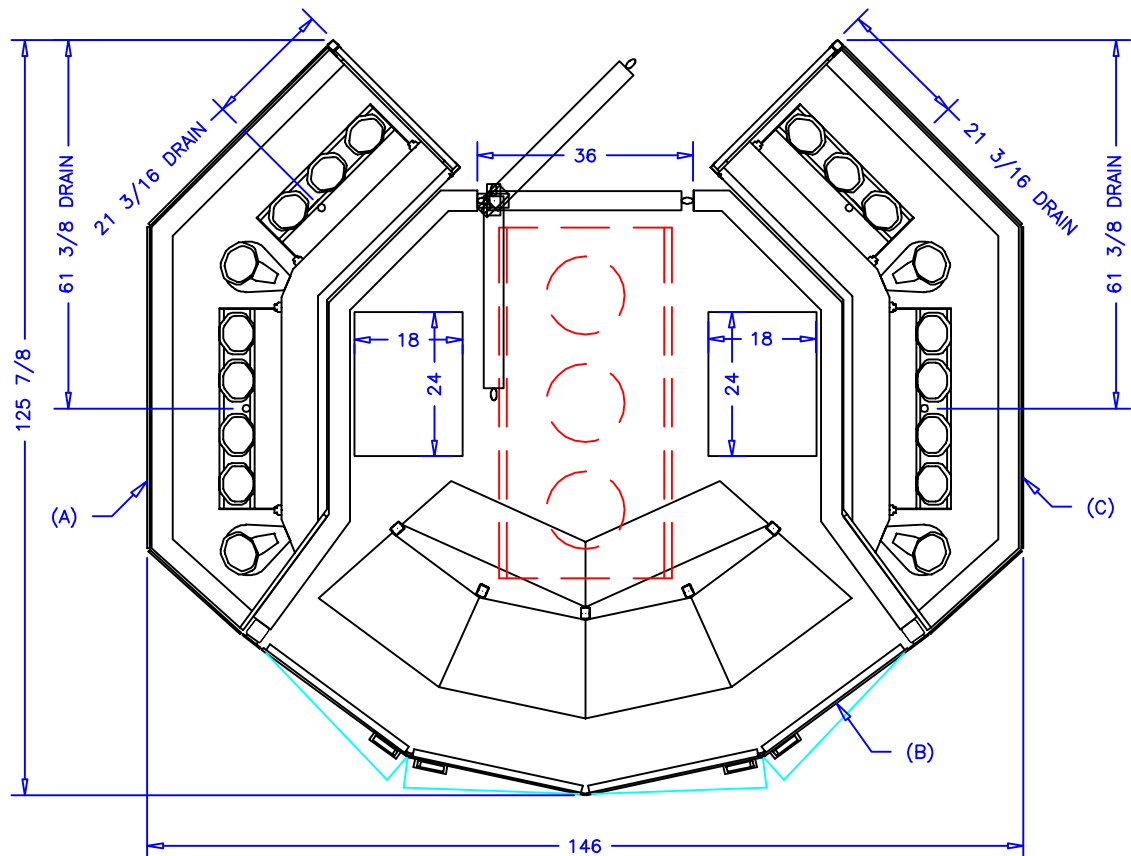

NOTES:

1. OPTIONS NOT SHOWN ON DRAWING SHOULD BE LISTED IN WRITTEN PROPOSAL AND LISTED ON PURCHASE ORDER.
2. ELEC. CONNECTION: 115V/230V, 4x4 SUPPLY BOX AS NEEDED.
3. EXPANSION VALVES: SPORLAN "Q" SERIES STANDARD UNLESS OTHERWISE SPECIFIED.
4. DEFROST CONTROL: REMOTE CASES (N/A, DIGITAL CASE CONTROLLERS AVAILABLE), OPTIONAL CONDENSING UNIT (DIGITAL CASE CONTROLLER).
5. THERMOSTATS & LIQUID LINE SOLENOID VALVES: OPTIONAL.
6. DRAIN: 1 1/2 INCH PVC.
7. SPECIFICATIONS SUBJECT TO CHANGE WITHOUT NOTICE.



| | | | | | | |
|------------------------|-------|-------------|----------------|---|------|------------------|
| AUTHORIZATION (PRINT): | DATE: | | |  börger systems | | DRAWN BY: D HUNT |
| SIGNATURE: | | 4-26-16 DRH | SCALE: 1:32 | | | CHECKED BY: |
| | | 3-28-16 DRH | DATE: 11-12-15 | 4DR WOD & (2) 9FT OPEN | | |
| | | 3-23-16 DRH | | | | |
| | | 3-14-16 DRH | | | | |
| | | DATE | REV. | DWG. | INCH | DRAWING NUMBER |
| | | REVISION | TOL: | | | P6943 |