

CASE SPECIFICATIONS:

REFRIGERATION:

CASE LOAD: 3,360 BTU/hr
 280 BTU/hr/ft
 COIL TEMP: 17° F
 LIQUID STUB: 3/8IN ODS
 SUCTION STUB: 5/8IN ODS

ELECTRICAL 115VAC, 60HZ, 1PH.
 FANS (5): 0.6A
 TOTAL: 0.6A

SUPER HEAT 8°F
 SET POINT 27°F
 DIFFERENTIAL 2°F
 DEFROST: 6HR INTERVALS FOR 35 MIN.

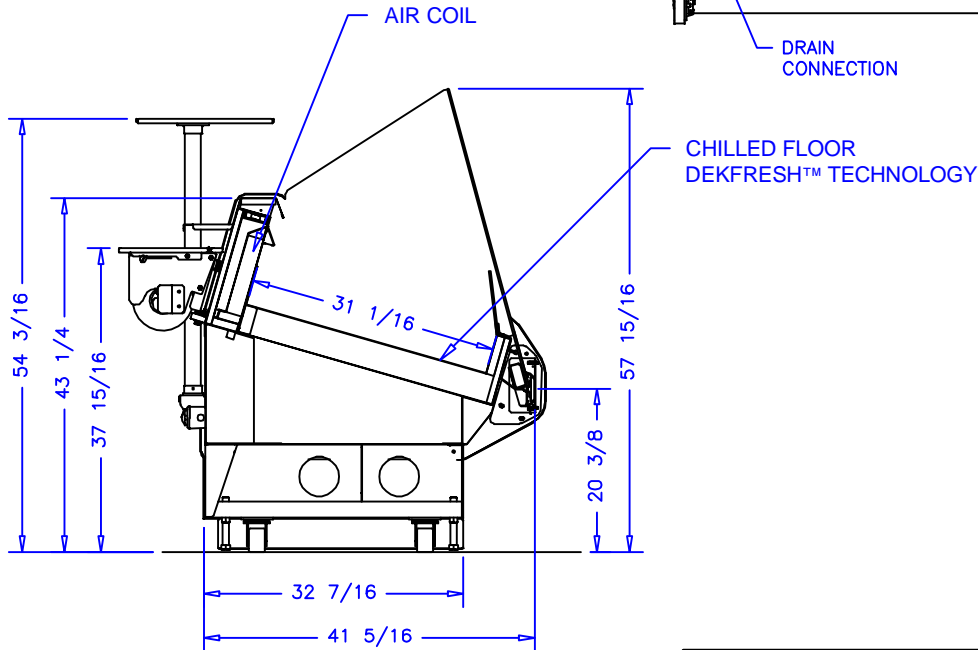
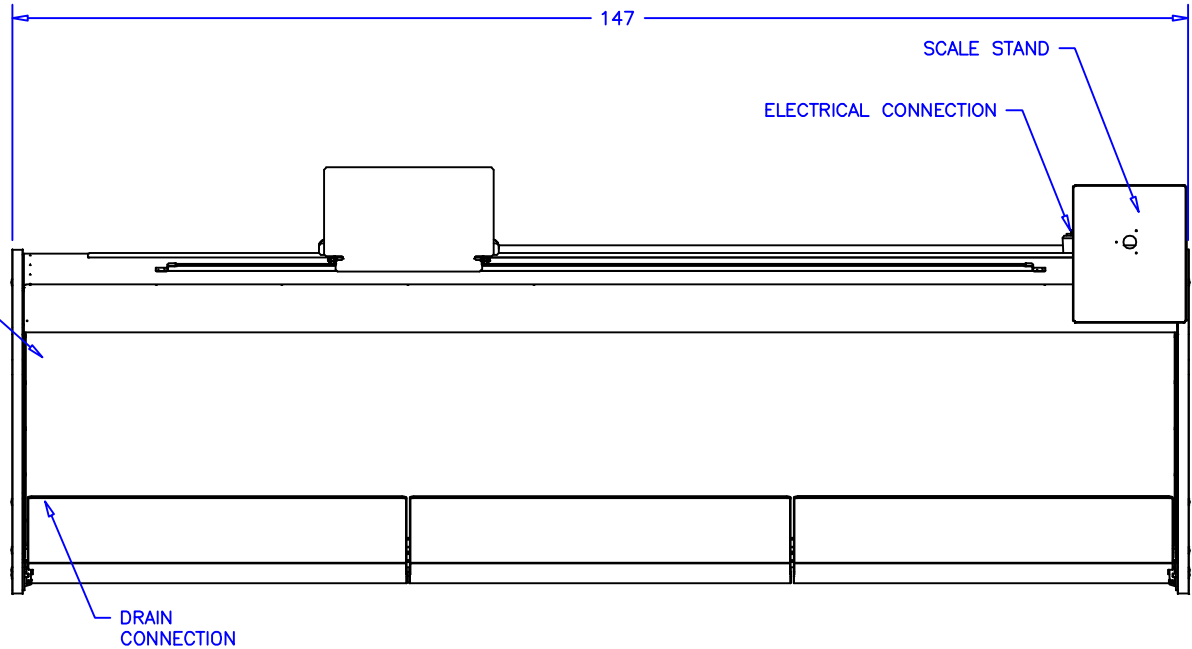

NOTES:

1. OPTIONS NOT SHOWN ON DRAWING SHOULD BE LISTED IN WRITTEN PROPOSAL AND LISTED ON PURCHASE ORDER.
2. ELEC. CONNECTION: 115V/230V, 4x4 SUPPLY BOX AS NEEDED.
3. EXPANSION VALVES: SPORLAN "Q" SERIES STANDARD UNLESS OTHERWISE SPECIFIED.
4. DEFROST CONTROL: REMOTE CASES (N/A, DIGITAL CASE CONTROLLERS AVAILABLE), OPTIONAL CONDENSING UNIT (DIGITAL CASE CONTROLLER).
5. THERMOSTATS & LIQUID LINE SOLENOID VALVES: OPTIONAL.
6. DRAIN: 1 1/2 INCH PVC.
7. SPECIFICATIONS SUBJECT TO CHANGE WITHOUT NOTICE.



AUTHORIZATION (PRINT): _____ DATE: _____

SIGNATURE: _____

		SCALE: 1:32	DRAWN BY: D HUNT
		DATE: 4-19-17	CHECKED BY:
12FT OPEN SERVICE GRAVITY+ DFT			
DATE	REV.	DWG. INCH	DRAWING NUMBER
REVISION	TOL:		P7317