

**CASE SPECIFICATIONS:**

**REFRIGERATION:**

CASE LOAD: 3,360 BTU/hr  
 280 BTU/hr/ft  
 COIL TEMP: 17° F  
 LIQUID STUB: 3/8IN ODS  
 SUCTION STUB: 5/8IN ODS

**ELECTRICAL 115VAC, 60HZ, 1PH.**

FANS: 0.6A  
 CONDENSATE PAN: 5.2A  
 1/2 HP COND. UNIT: 9.2A  
 TOTAL: 15.0A  
 MCA: 18.7A

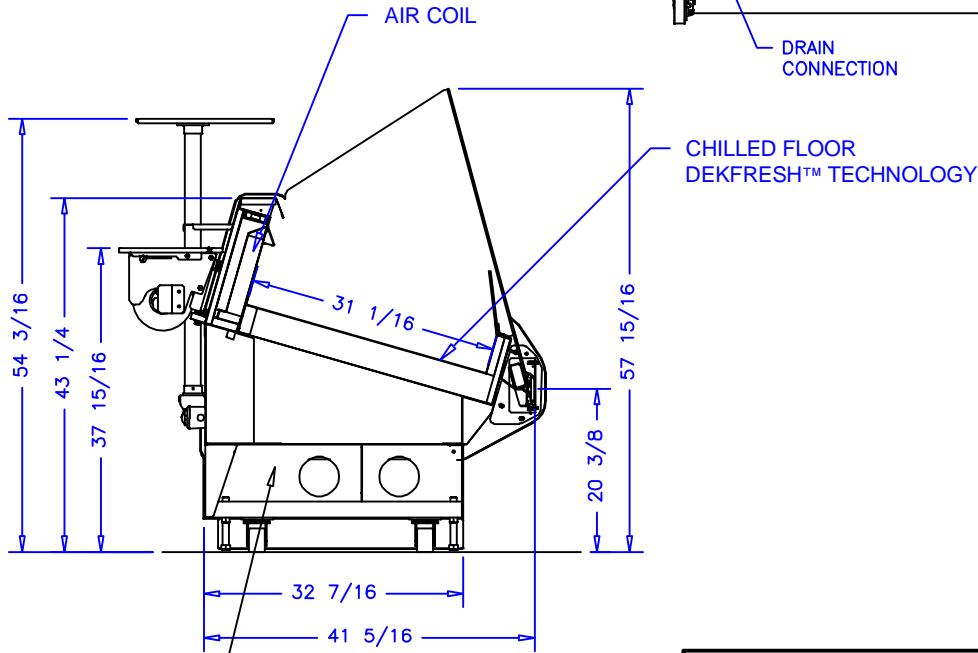
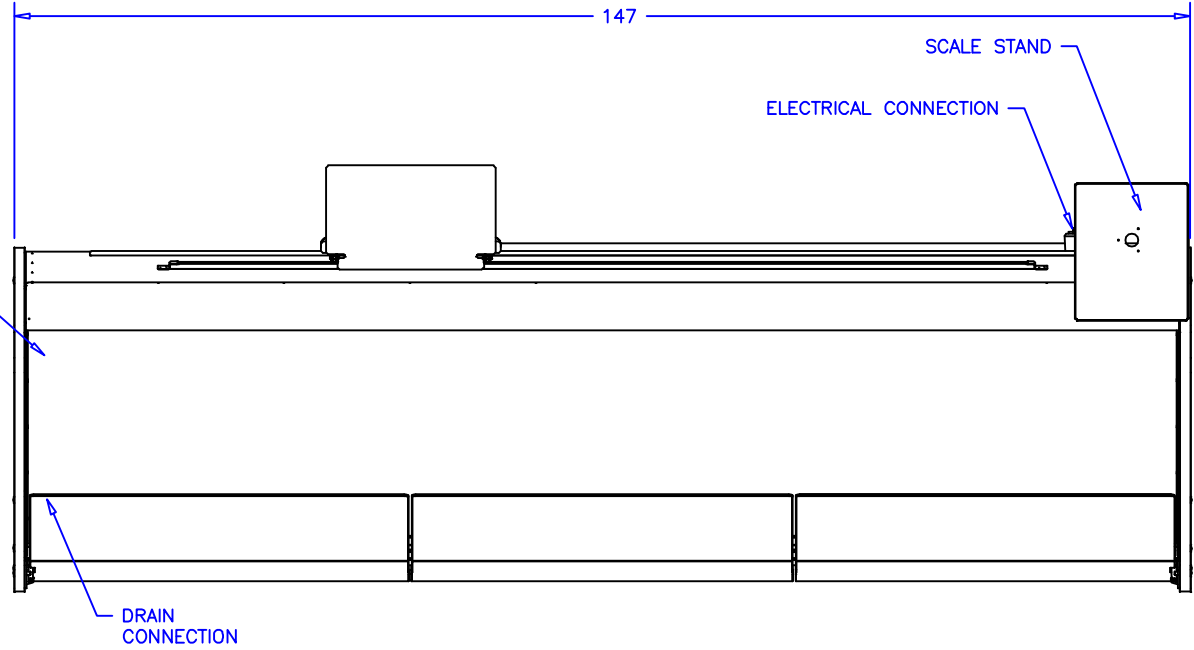

CONDENSING UNIT LOCATION



**NOTES:**

1. OPTIONS NOT SHOWN ON DRAWING SHOULD BE LISTED IN WRITTEN PROPOSAL AND LISTED ON PURCHASE ORDER.
2. ELEC. CONNECTION: 115V/230V, 4x4 SUPPLY BOX AS NEEDED.
3. EXPANSION VALVES: SPORLAN "Q" SERIES STANDARD UNLESS OTHERWISE SPECIFIED.
4. DEFROST CONTROL: REMOTE CASES (N/A, DIGITAL CASE CONTROLLERS AVAILABLE), OPTIONAL CONDENSING UNIT (DIGITAL CASE CONTROLLER).
5. THERMOSTATS & LIQUID LINE SOLENOID VALVES: OPTIONAL.
6. DRAIN: 1 1/2 INCH PVC.
7. SPECIFICATIONS SUBJECT TO CHANGE WITHOUT NOTICE.

AUTHORIZATION (PRINT):		DATE:				SCALE: 1:32		DRAWN BY: D HUNT	
SIGNATURE:						DATE: 4-19-17		CHECKED BY:	
12FT OPEN SERVICE GRAVITY+ DFT						DATE		REV.	
						DIM: INCH		DRAWING NUMBER	
						REVISION		TOL:	
								P7317	