

CASE SPECIFICATIONS:

REFRIGERATION:  
CASE LOAD: 2,240 BTU/hr  
280 BTU/hr/ft  
COIL TEMP: 17° F  
LIQUID STUB: 3/8IN ODS  
SUCTION STUB: 5/8IN ODS

ELECTRICAL 115VAC, 60HZ, 1PH.  
FANS (3): 0.36A  
TOTAL: 0.36A

SUPER HEAT 8°F  
SET POINT 27°F  
DIFFERENTIAL 2°F  
DEFROST: 6HR INTERVALS FOR 35 MIN.

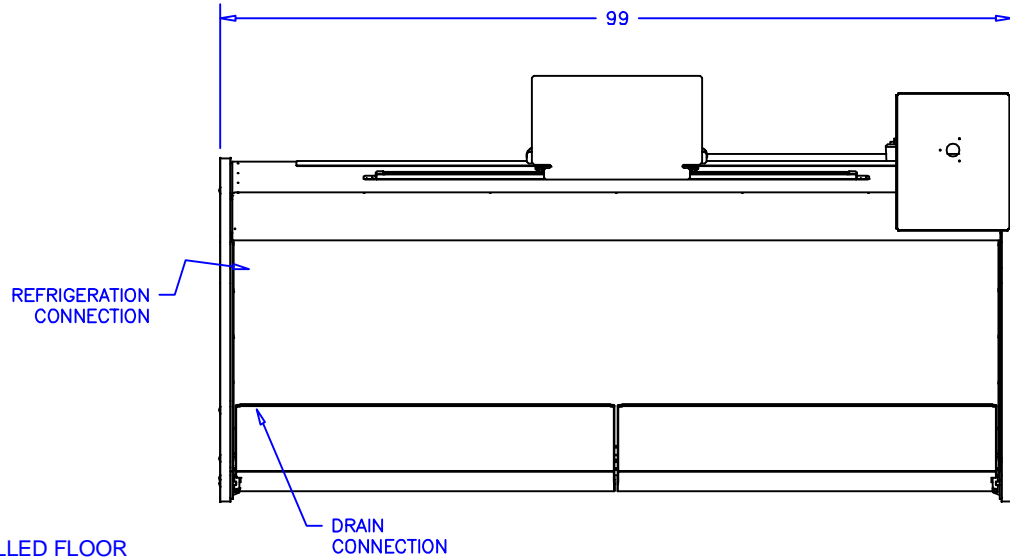
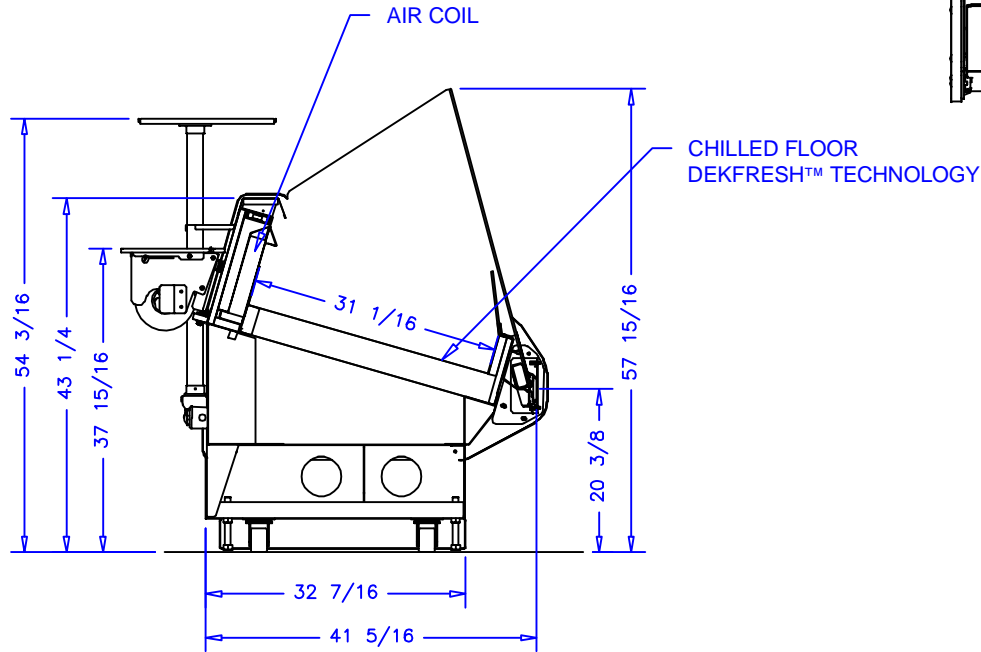

NOTES:

1. OPTIONS NOT SHOWN ON DRAWING SHOULD BE LISTED IN WRITTEN PROPOSAL AND LISTED ON PURCHASE ORDER.
2. ELEC. CONNECTION: 115V/230V, 4x4 SUPPLY BOX AS NEEDED.
3. EXPANSION VALVES: SPORLAN "Q" SERIES STANDARD UNLESS OTHERWISE SPECIFIED.
4. DEFROST CONTROL: REMOTE CASES (N/A, DIGITAL CASE CONTROLLERS AVAILABLE), OPTIONAL CONDENSING UNIT (DIGITAL CASE CONTROLLER).
5. THERMOSTATS & LIQUID LINE SOLENOID VALVES: OPTIONAL.
6. DRAIN: 1 1/2 INCH PVC.
7. SPECIFICATIONS SUBJECT TO CHANGE WITHOUT NOTICE.



AUTHORIZATION (PRINT):		DATE:		 <b>börgeren systems</b>		DRAWN BY: D HUNT	
SIGNATURE:						CHECKED BY:	
		SCALE: 1:32		8FT OPEN SERVICE DFT			
		DATE: 9-27-16		5-6-17 DRH			
		DATE		REV.		DIN: INCH	
		REVISION		TOL:		DRAWING NUMBER	
						P7106	