

CASE SPECIFICATIONS:

REFRIGERATION:
CASE LOAD: 2,240 BTU/hr
280 BTU/hr/ft
COIL TEMP: 17° F
LIQUID STUB: 3/8IN ODS
SUCTION STUB: 5/8IN ODS

ELECTRICAL 115VAC, 60HZ, 1PH.
FANS: 0.36A
CONDENSATE PAN: 5.2A
1/2 HP COND. UNIT: 9.2A
TOTAL: 14.76A
MCA: 18.46A

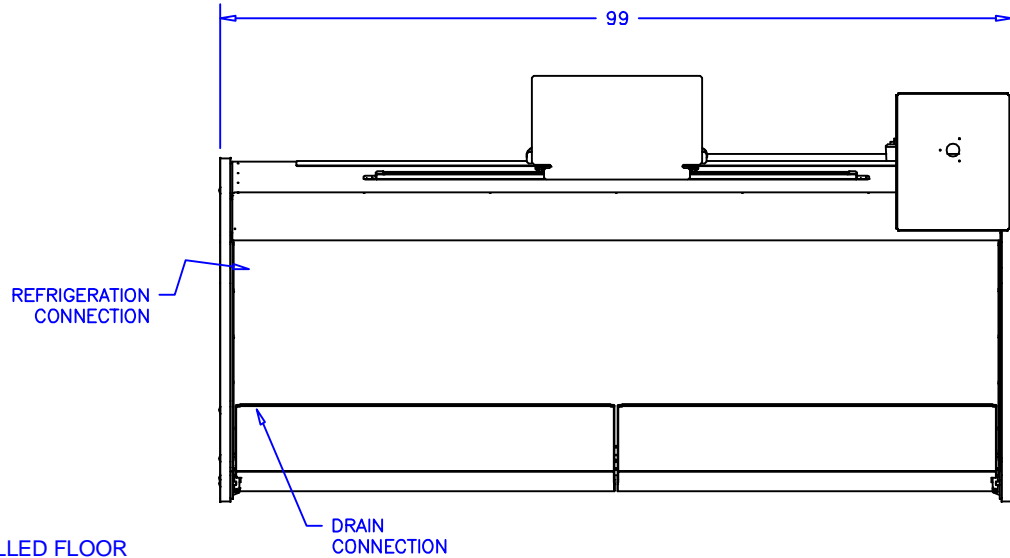
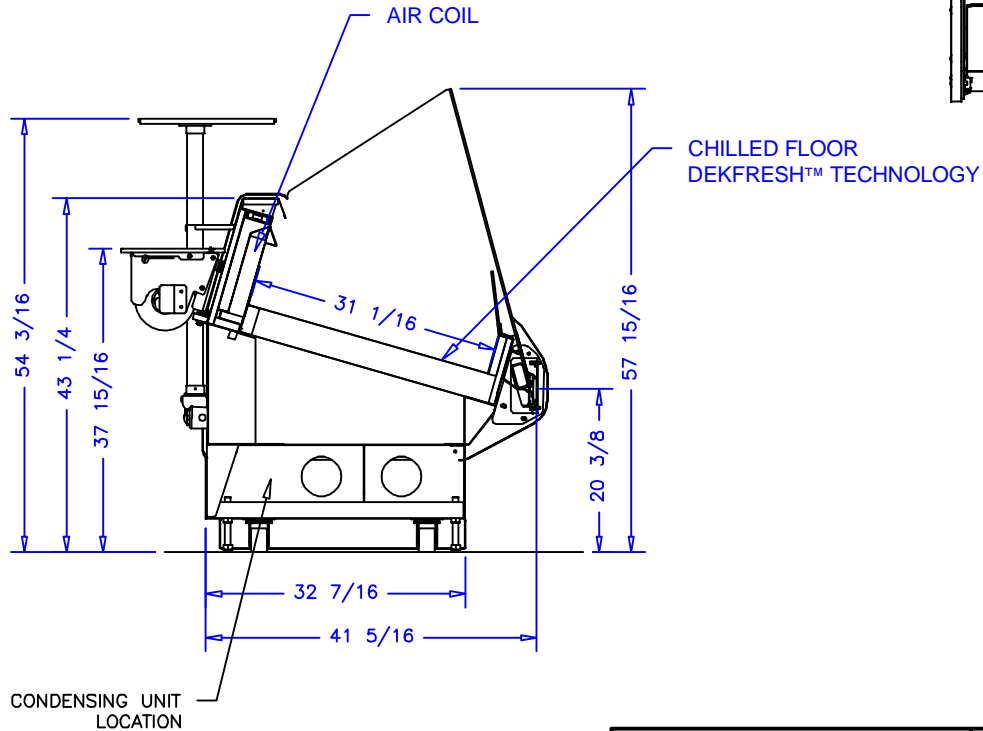

NOTES:

1. OPTIONS NOT SHOWN ON DRAWING SHOULD BE LISTED IN WRITTEN PROPOSAL AND LISTED ON PURCHASE ORDER.
2. ELEC. CONNECTION: 115V/230V, 4x4 SUPPLY BOX AS NEEDED.
3. EXPANSION VALVES: SPORLAN "Q" SERIES STANDARD UNLESS OTHERWISE SPECIFIED.
4. DEFROST CONTROL: REMOTE CASES (N/A, DIGITAL CASE CONTROLLERS AVAILABLE), OPTIONAL CONDENSING UNIT (DIGITAL CASE CONTROLLER).
5. THERMOSTATS & LIQUID LINE SOLENOID VALVES: OPTIONAL.
6. DRAIN: 1 1/2 INCH PVC.
7. SPECIFICATIONS SUBJECT TO CHANGE WITHOUT NOTICE.



AUTHORIZATION (PRINT):	DATE:			SCALE: 1:32	DRAWN BY: D HUNT
SIGNATURE:				DATE: 9-27-16	CHECKED BY:
		5-6-17 DRH		8FT OPEN SERVICE DFT	
DATE	REV.	DATE	INCH	DRAWING NUMBER	
REVISION	TOL:			P7106	