

CASE SPECIFICATIONS:

REFRIGERATION:

LOAD: 4,200 BTU/hr
 SUCTION TEMP: 30°F
 SUCTION LINE: 5/8IN ODS
 LIQUID LINE: 3/8IN ODS

ELECTRICAL 115V, 60HZ, 1PH
 EVAP. FANS: 0.60A
 LIGHTS: 4.8A
 TOTAL: 5.4A

OPTIONAL ELECTRICAL 115V, 60HZ, 1PH
 1/2 HP COND. UNIT: 9.2A
 CONDENSATE PUMP: 1.0A
 CONDENSATE PAN: 3.0A
 TOTAL: 13.2A

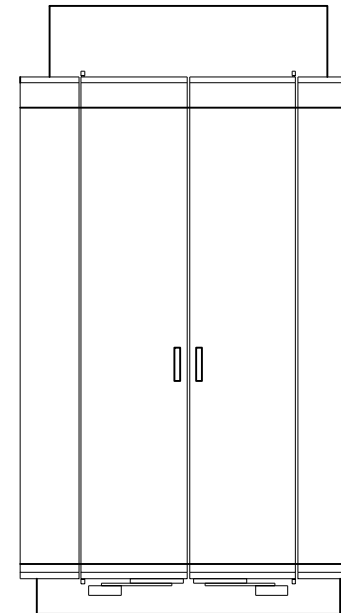
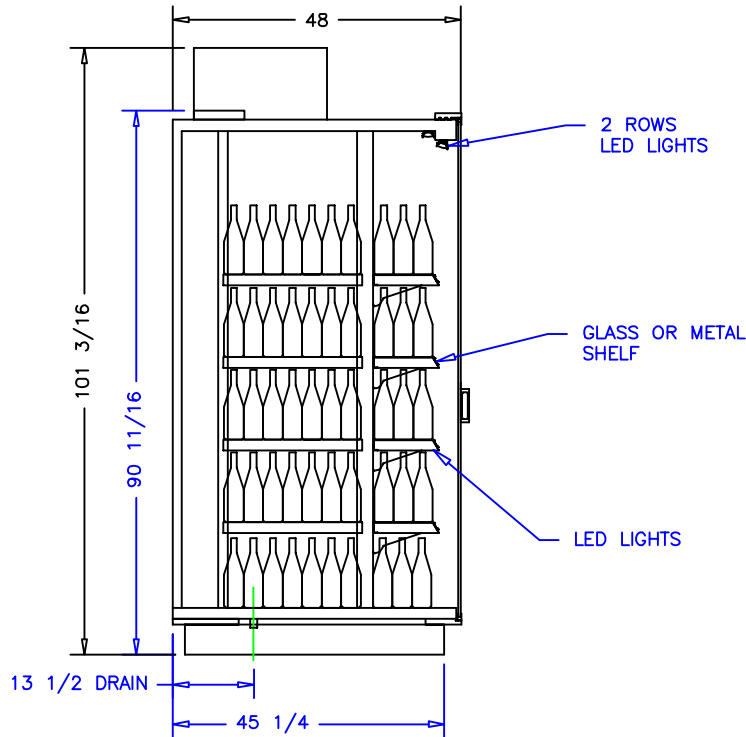
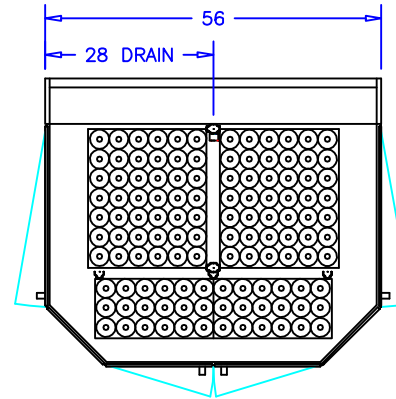

NOTES:

1. OPTIONS NOT SHOWN ON DRAWING SHOULD BE LISTED IN WRITTEN PROPOSAL AND LISTED ON PURCHASE ORDER.
2. ELEC. CONNECTION: 115V/230V, 4x4 SUPPLY BOX AS NEEDED.
3. EXPANSION VALVES: SPORLAN "Q" SERIES STANDARD UNLESS OTHERWISE SPECIFIED.
4. DEFROST CONTROL: REMOTE CASES (N/A, DIGITAL CASE CONTROLLERS AVAILABLE), OPTIONAL CONDENSING UNIT (DIGITAL CASE CONTROLLER).
5. THERMOSTATS & LIQUID LINE SOLENOID VALVES: OPTIONAL.
6. DRAIN: 1 1/2 INCH PVC.
7. SPECIFICATIONS SUBJECT TO CHANGE WITHOUT NOTICE.

AUTHORIZATION (PRINT):		DATE:		 börgeren systems		DRAWN BY: D HUNT	
SIGNATURE:						CHECKED BY:	
				SCALE: 1:32			
				DATE: 5-2-17			
4DR WINE END CAP TALL							
DATE		REV.		Dwg: INCH		DRAWING NUMBER	
REVISION				PQ20		P7324	