

CASE SPECIFICATIONS:

REFRIGERATION:

LOAD: 3,900 BTU/hr
 COIL TEMP: 25°F
 SUCTION STUB: 5/8IN ODS
 LIQUID STUB: 3/8IN ODS

ELECTRICAL 115V, 60HZ, 1PH
 EVAP. FANS: 0.60A
 LED LIGHT: 2.4A
 CONDENSATE PUMP: 1.0A
 CONDENSATE PAN: 5.2A
 TOTAL: 9.2A
 MCA: 15.0A

ELECTRICAL 208/230V, 60HZ, 1PH
 3/4 HP COND. UNIT: 6.8A
 TOTAL: 6.8A
 MCA: 9.6A

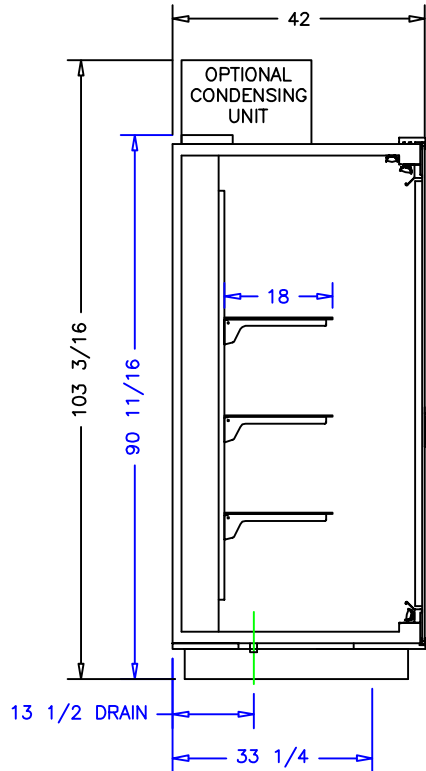
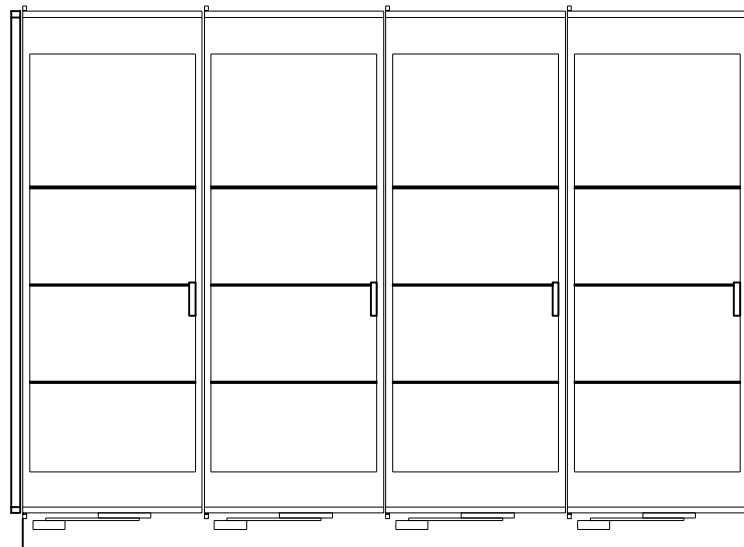
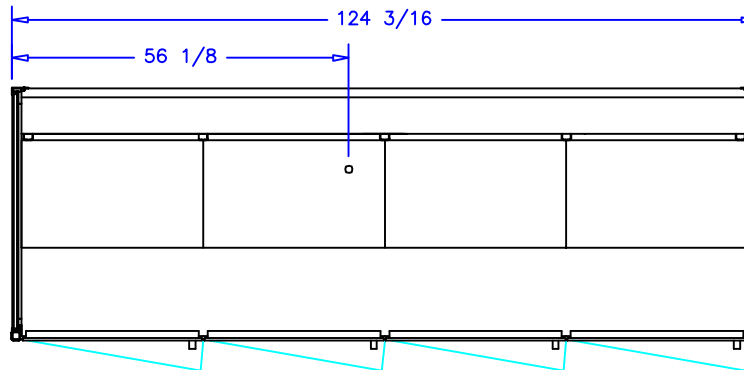

NOTES:

1. OPTIONS NOT SHOWN ON DRAWING SHOULD BE LISTED IN WRITTEN PROPOSAL AND LISTED ON PURCHASE ORDER.
2. ELEC. CONNECTION: 115V/230V, 4x4 SUPPLY BOX AS NEEDED.
3. EXPANSION VALVES: SPORLAN "Q" SERIES STANDARD UNLESS OTHERWISE SPECIFIED.
4. DEFROST CONTROL: REMOTE CASES (N/A, DIGITAL CASE CONTROLLERS AVAILABLE), OPTIONAL CONDENSING UNIT (DIGITAL CASE CONTROLLER).
5. THERMOSTATS & LIQUID LINE SOLENOID VALVES: OPTIONAL.
6. DRAIN: 1 1/2 INCH PVC.
7. SPECIFICATIONS SUBJECT TO CHANGE WITHOUT NOTICE.



AUTHORIZATION (PRINT):		DATE:		 börgeren systems		SCALE: 1:32		DRAWN BY: D HUNT	
						DATE: 4-28-16		CHECKED BY:	
				4 DOOR TALL DP					
DATE		REV.		DIM:		INCH		DRAWING NUMBER	
REVISION		TOL:						P7081	