

CASE SPECIFICATIONS:

REFRIGERATION:

CASE LOAD: 2,240 BTU/hr
 280 BTU/hr/ft
 COIL TEMP: 17° F
 LIQUID STUB: 3/8IN ODS
 SUCTION STUB: 5/8IN ODS

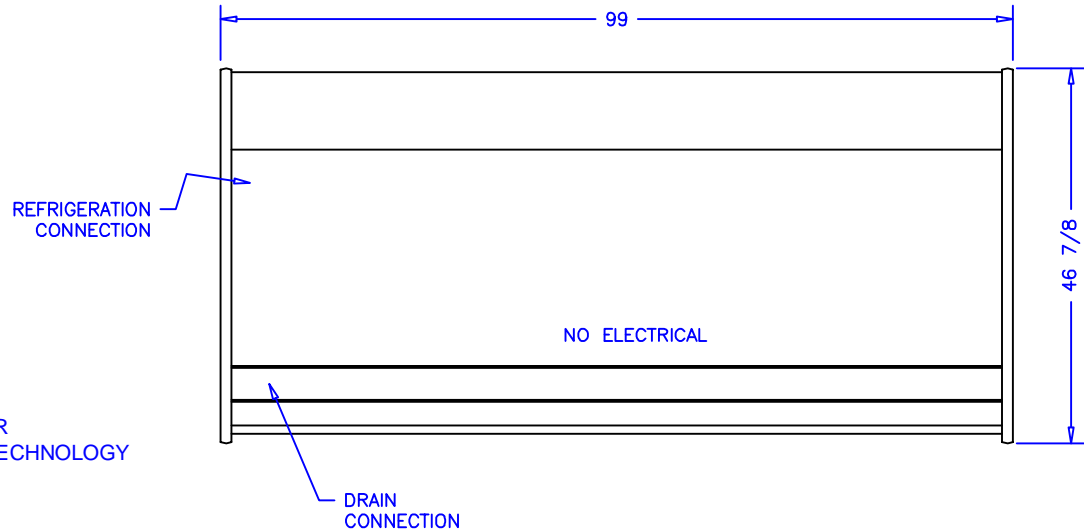
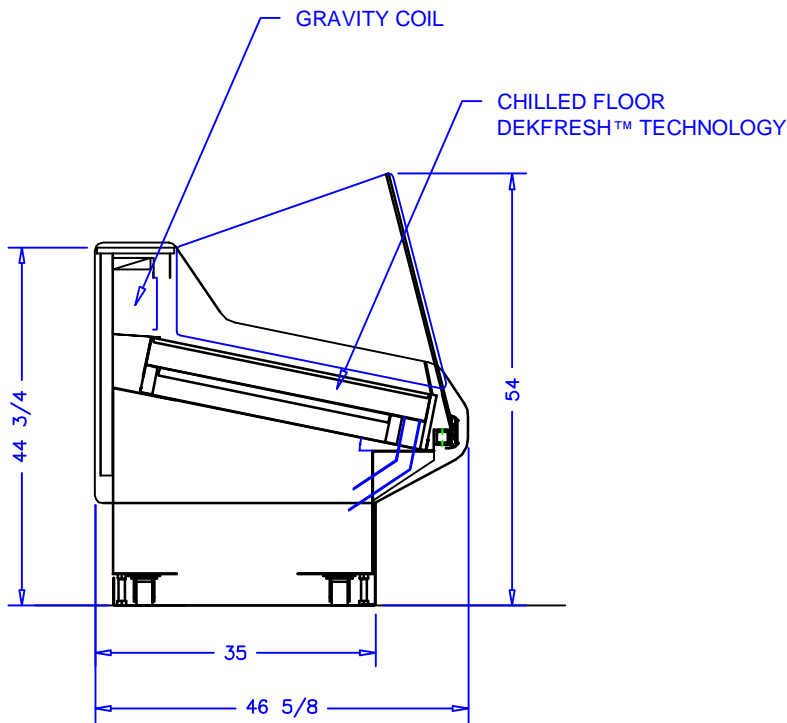

NOTES:

1. OPTIONS NOT SHOWN ON DRAWING SHOULD BE LISTED IN WRITTEN PROPOSAL AND LISTED ON PURCHASE ORDER.
2. ELEC. CONNECTION: 115V/230V, 4x4 SUPPLY BOX AS NEEDED.
3. EXPANSION VALVES: SPORLAN "Q" SERIES STANDARD UNLESS OTHERWISE SPECIFIED.
4. DEFROST CONTROL: REMOTE CASES (N/A, DIGITAL CASE CONTROLLERS AVAILABLE), OPTIONAL CONDENSING UNIT (DIGITAL CASE CONTROLLER).
5. THERMOSTATS & LIQUID LINE SOLENOID VALVES: OPTIONAL.
6. DRAIN: 1 1/2 INCH PVC.
7. SPECIFICATIONS SUBJECT TO CHANGE WITHOUT NOTICE.



AUTHORIZATION (PRINT):	DATE:	 börgeren systems		SCALE: 1:32	DRAWN BY: D HUNT
SIGNATURE:				DATE: 4-15-15	CHECKED BY:
		7-28-15 DRH	8FT OPEN SERVICE GRAVITY+ DFT		
		7-21-15 DRH			
		6-15-15 DRH			
DATE	REV.	DIM:	INCH	DRAWING NUMBER	
REVISION	TOL:			P6823	