

CASE SPECIFICATIONS:

REFRIGERATION:

LOAD: 3,036 BTU/hr  
 SUCTION TEMP: 30°F  
 SUCTION LINE: 5/8IN ODS  
 LIQUID LINE: 3/8IN ODS

ELECTRICAL 115V, 60HZ, 1PH  
 EVAP. FANS: 0.30A  
 LED LIGHTS: 2.4A  
 TOTAL: 2.7A  
 MCA: 15.0A

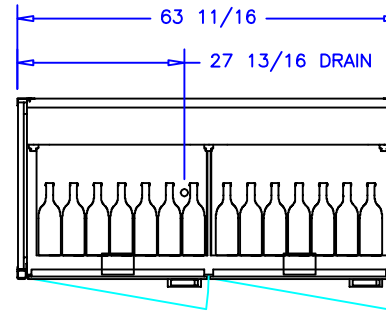

BOTTLES PER DOOR: 67  
 TOTAL FOR CASE: 134

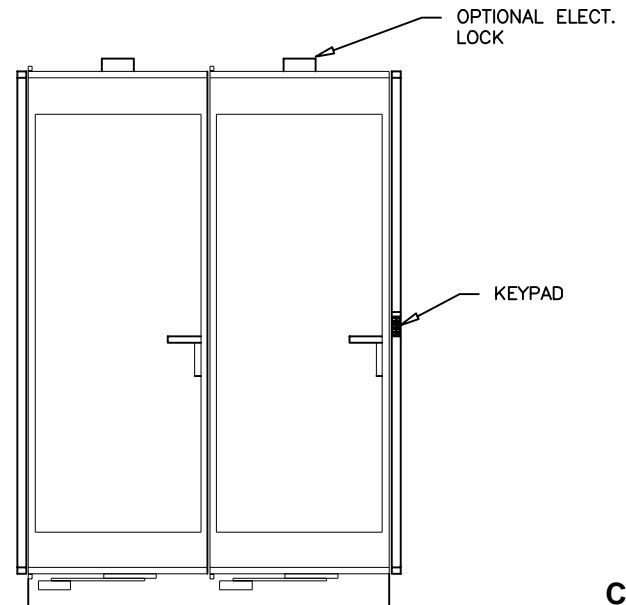
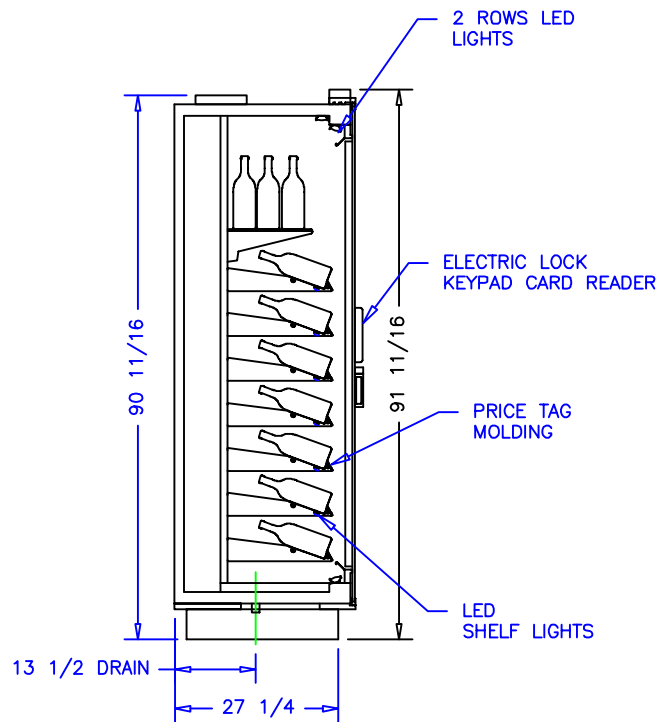

NOTES:

1. OPTIONS NOT SHOWN ON DRAWING SHOULD BE LISTED IN WRITTEN PROPOSAL AND LISTED ON PURCHASE ORDER.
2. ELEC. CONNECTION: 115V/230V, 4x4 SUPPLY BOX AS NEEDED.
3. EXPANSION VALVES: SPORLAN "Q" SERIES STANDARD UNLESS OTHERWISE SPECIFIED.
4. DEFROST CONTROL: REMOTE CASES (N/A, DIGITAL CASE CONTROLLERS AVAILABLE), OPTIONAL CONDENSING UNIT (DIGITAL CASE CONTROLLER).
5. THERMOSTATS & LIQUID LINE SOLENOID VALVES: OPTIONAL.
6. DRAIN: 1 1/2 INCH PVC.
7. SPECIFICATIONS SUBJECT TO CHANGE WITHOUT NOTICE.

|                        |      |       |      |   |  |                  |  |                |
|------------------------|------|-------|------|---|--|------------------|--|----------------|
| AUTHORIZATION (PRINT): |      | DATE: |      |  <b>börgeren systems</b> |  | DRAWN BY: D HUNT |  |                |
|                        |      |       |      |   |  | CHECKED BY:      |  |                |
|                        |      |       |      | SCALE: 1:32   |  |                  |  |                |
|                        |      |       |      | DATE: 10-13-14  |  |                  |  |                |
| 2 DOOR WINE TALL       |      |       |      |   |  |                  |  |                |
| DATE                   | REV. | DR:   | INCH |   |  |                  |  | DRAWING NUMBER |
| REVISION               | TOL: |       |      |   |  |                  |  |                |