

CASE SPECIFICATIONS:

REFRIGERATION:

LOAD: 3,036 BTU/hr  
 SUCTION TEMP: 30°F  
 SUCTION LINE: 5/8IN ODS  
 LIQUID LINE: 3/8IN ODS

ELECTRICAL 115V, 60HZ, 1PH

EVAP. FANS: 0.30A  
 LED LIGHTS: 2.4A  
 TOTAL: 2.7A  
 MCA: 15.0A

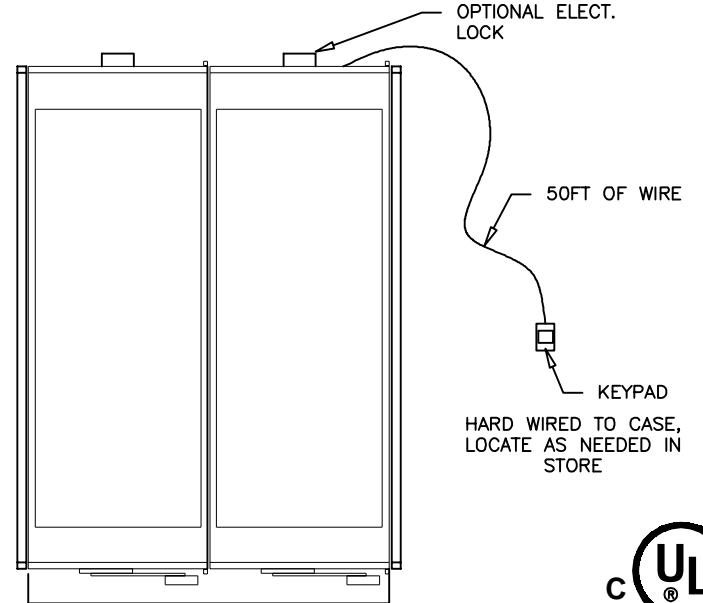
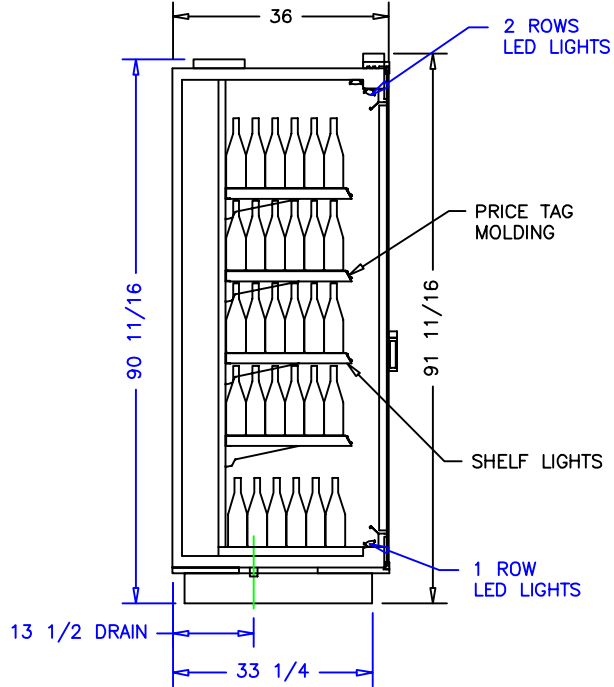
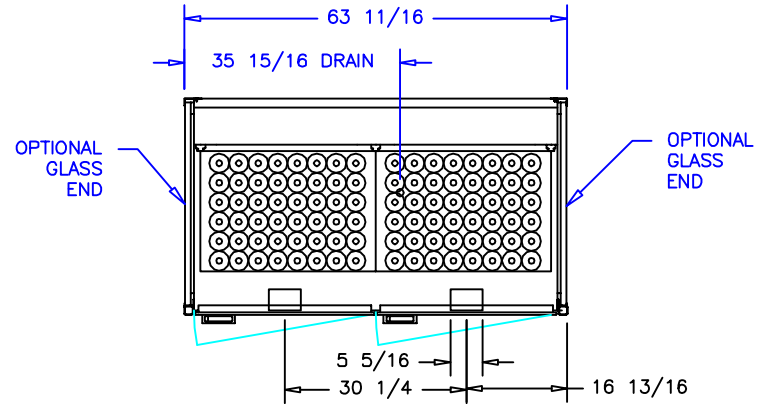

NOTES:

1. OPTIONS NOT SHOWN ON DRAWING SHOULD BE LISTED IN WRITTEN PROPOSAL AND LISTED ON PURCHASE ORDER.
2. ELEC. CONNECTION: 115V/230V, 4x4 SUPPLY BOX AS NEEDED.
3. EXPANSION VALVES: SPORLAN "Q" SERIES STANDARD UNLESS OTHERWISE SPECIFIED.
4. DEFROST CONTROL: REMOTE CASES (N/A, DIGITAL CASE CONTROLLERS AVAILABLE), OPTIONAL CONDENSING UNIT (DIGITAL CASE CONTROLLER).
5. THERMOSTATS & LIQUID LINE SOLENOID VALVES: OPTIONAL.
6. DRAIN: 1 1/2 INCH PVC.
7. SPECIFICATIONS SUBJECT TO CHANGE WITHOUT NOTICE.

AUTHORIZATION (PRINT):	DATE:	 <b>börgeren systems</b>		SCALE: 1:32	DRAWN BY: D HUNT
				DATE: 9-3-14	CHECKED BY:
		2 DOOR WINE TALL			
DATE	REV.	DR:	INCH	DRAWING NUMBER	
				P6705	
REVISION		TOL:			