

CASE SPECIFICATIONS:

REFRIGERATION:

LOAD: 2,300 BTU/hr
 COIL TEMP: 30°F
 SUCTION STUB: 5/8IN ODS
 LIQUID STUB: 3/8IN ODS

ELECTRICAL 115V, 60HZ, 1PH
 EVAP. FANS: 0.3A
 LIGHTS: 2.4A
 CONDENSATE PUMP: 1.0A
 CONDENSATE PAN: 3.0A
 1/3 HP COND. UNIT: 6.0A
 TOTAL: 12.7A
 MCA: 25.0A

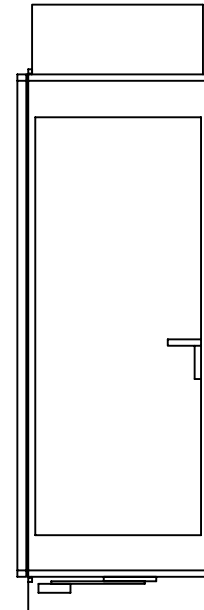
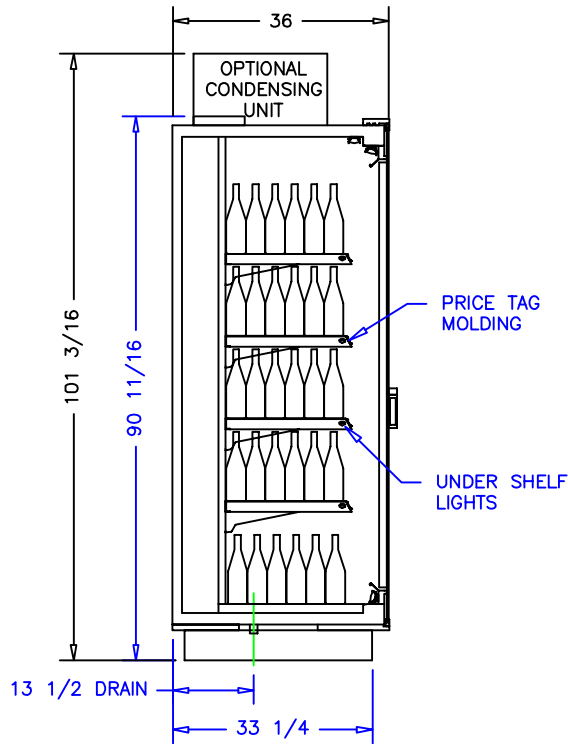
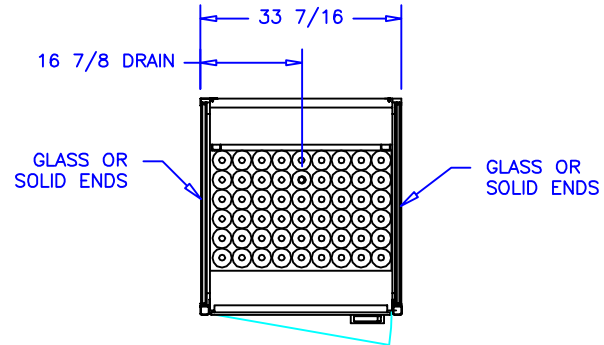

NOTES:

1. OPTIONS NOT SHOWN ON DRAWING SHOULD BE LISTED IN WRITTEN PROPOSAL AND LISTED ON PURCHASE ORDER.
2. ELEC. CONNECTION: 115V/230V, 4x4 SUPPLY BOX AS NEEDED.
3. EXPANSION VALVES: SPORLAN "Q" SERIES STANDARD UNLESS OTHERWISE SPECIFIED.
4. DEFROST CONTROL: REMOTE CASES (N/A, DIGITAL CASE CONTROLLERS AVAILABLE), OPTIONAL CONDENSING UNIT (DIGITAL CASE CONTROLLER).
5. THERMOSTATS & LIQUID LINE SOLENOID VALVES: OPTIONAL.
6. DRAIN: 1 1/2 INCH PVC.
7. SPECIFICATIONS SUBJECT TO CHANGE WITHOUT NOTICE.

AUTHORIZATION (PRINT):		DATE:		 börigen systems		SCALE: 1:32		DRAWN BY: D HUNT	
						DATE: 7-30-14		CHECKED BY:	
				2-12-15 DRH		1DR WINE TALL			
DATE		REV.		DIM: INCH		DRAWING NUMBER		P6693	
REVISION		TOL:							