

CASE SPECIFICATIONS:

REFRIGERATION:

LOAD: 3,400 BTU/hr
 COIL TEMP: 30°F
 SUCTION STUB: 5/8IN ODS
 LIQUID STUB: 3/8IN ODS

ELECTRICAL 115V, 60HZ, 1PH
 EVAP. FANS: 0.30A
 CASE LIGHTS: 3.6A
 SHELF LIGHTS: 2.4A
 TOTAL: 6.3A
 MCA: 15.0A

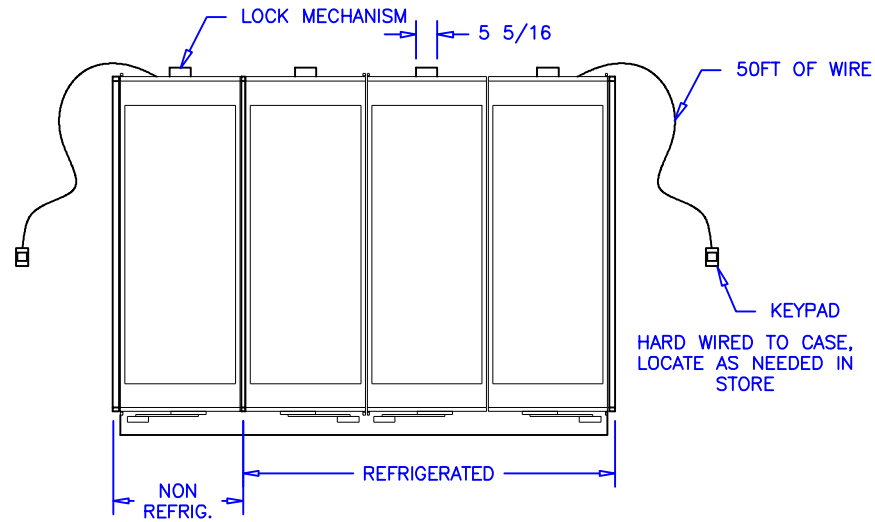
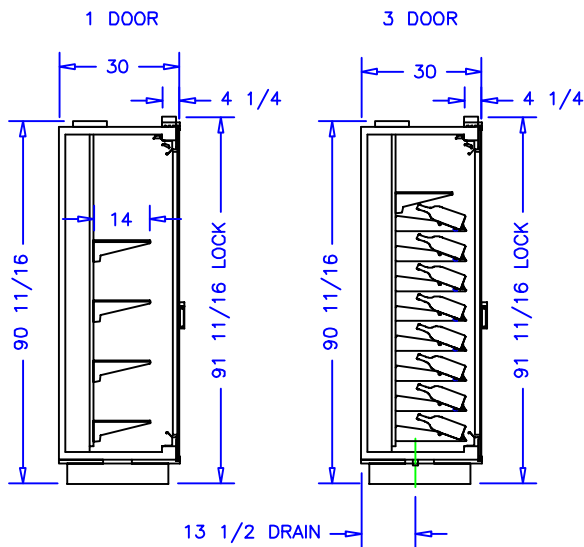
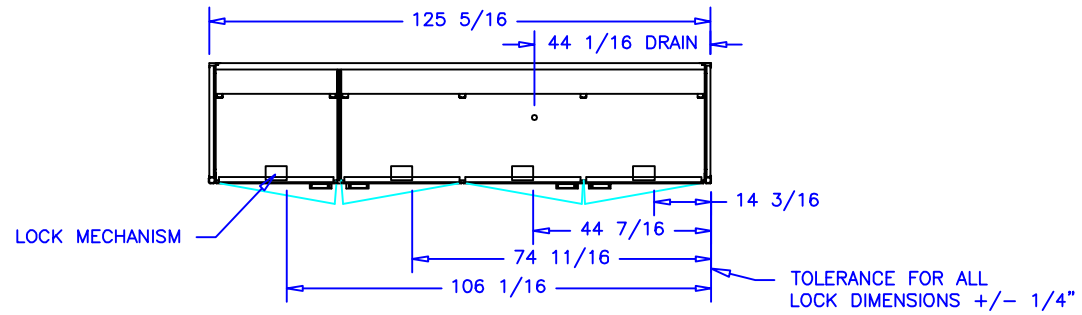

NOTES:

1. OPTIONS NOT SHOWN ON DRAWING SHOULD BE LISTED IN WRITTEN PROPOSAL AND LISTED ON PURCHASE ORDER.
2. ELEC. CONNECTION: 115V/230V, 4x4 SUPPLY BOX AS NEEDED.
3. EXPANSION VALVES: SPORLAN "Q" SERIES STANDARD UNLESS OTHERWISE SPECIFIED.
4. DEFROST CONTROL: REMOTE CASES (N/A, DIGITAL CASE CONTROLLERS AVAILABLE), OPTIONAL CONDENSING UNIT (DIGITAL CASE CONTROLLER).
5. THERMOSTATS & LIQUID LINE SOLENOID VALVES: OPTIONAL.
6. DRAIN: 1 1/2 INCH PVC.
7. SPECIFICATIONS SUBJECT TO CHANGE WITHOUT NOTICE.

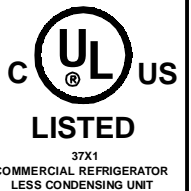

AUTHORIZATION (PRINT):	DATE:					SCALE: 1:48	DRAWN BY: D HUNT
						DATE: 2-3-14	CHECKED BY:
				4DR WINE TALL			
DATE	REV.	DR:	INCH			DRAWING NUMBER	
REVISION		TOL:				P6586	