

BOTTLE CAPACITY: 364

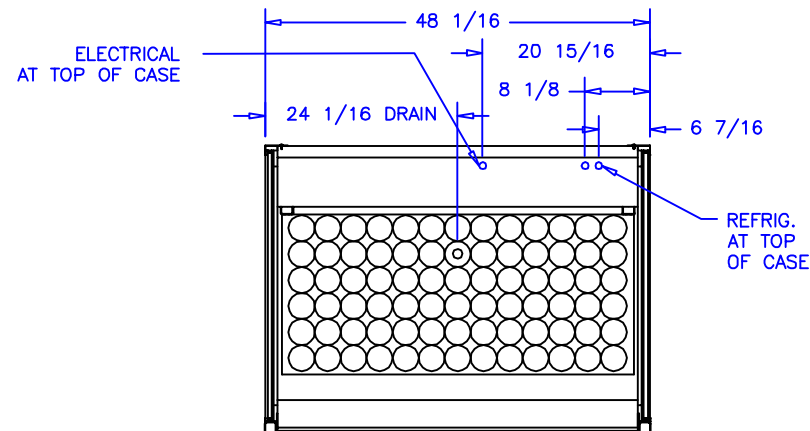

CASE SPECIFICATIONS:

REFRIGERATION  
 LOAD: 5,500 BTU/hr  
 COIL TEMP: 30° F  
 LIQUID STUB: 3/8IN ODS  
 SUCTION STUB: 5/8IN ODS

ELECTRICAL 115VAC, 60HZ, 1PH.  
 EVAP. FANS: .30A  
 LED LIGHTS: 2.4A  
 CONDENSATE PUMP: 1.0A  
 TOTAL: 3.7A  
 MCA: 15.0A

ELECTRICAL 230VAC, 60HZ, 1PH.  
 EVAP. PAN: 7.2A  
 3/4HP COND. UNIT: 6.1A  
 TOTAL: 13.3A  
 MCA: 15.3A



NOTES:

1. OPTIONS NOT SHOWN ON DRAWING SHOULD BE LISTED IN WRITTEN PROPOSAL AND LISTED ON PURCHASE ORDER.
2. ELEC. CONNECTION: 115V/230V, 4x4 SUPPLY BOX AS NEEDED.
3. EXPANSION VALVES: SPORLAN "Q" SERIES STANDARD UNLESS OTHERWISE SPECIFIED.
4. DEFROST CONTROL: REMOTE CASES (N/A, DIGITAL CASE CONTROLLERS AVAILABLE), OPTIONAL CONDENSING UNIT (DIGITAL CASE CONTROLLER).
5. THERMOSTATS & LIQUID LINE SOLENOID VALVES: OPTIONAL.
6. DRAIN: 1 1/2 INCH PVC.
7. SPECIFICATIONS SUBJECT TO CHANGE WITHOUT NOTICE.

|                        |      |       |      |   |             |
|------------------------|------|-------|------|---|-------------|
| AUTHORIZATION (PRINT): |      | DATE: |      |  <b>börger systems</b> |             |
| SIGNATURE:             |      |       |      |   |             |
|                        |      |       |      | DATE: 1-6-14  | CHECKED BY: |
|                        |      |       |      | 4FT HC WINE   |             |
| DATE                   | REV. | DWG.  | INCH | DRAWING NUMBER  |             |
| REVISION               | TOL: |       |      | P6566   |             |