

CASE SPECIFICATIONS:

REFRIGERATION:

LOAD: 5,900 BTU/hr
 COIL TEMP: 30°F
 SUCTION STUB: 5/8IN ODS
 LIQUID STUB: 3/8IN ODS

ELECTRICAL 115V, 60HZ, 1PH
 EVAP. FANS: 0.60A
 LIGHT BALLASTS: 3.7A
 TOTAL: 4.3A
 MCA: 15.0A

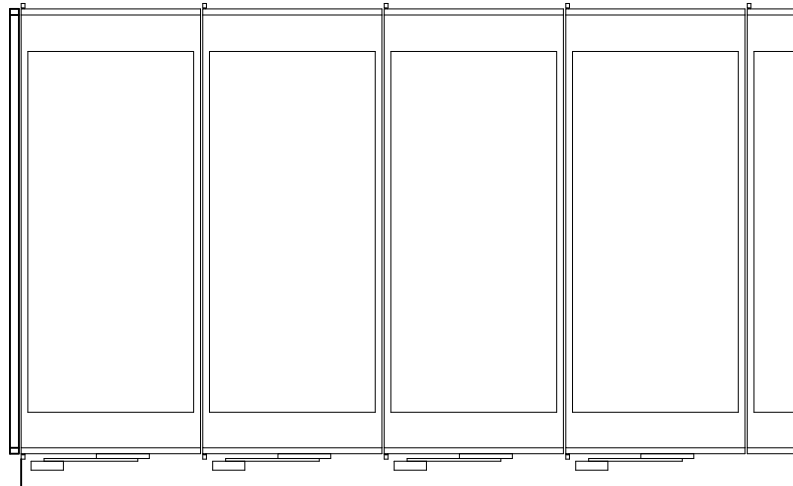
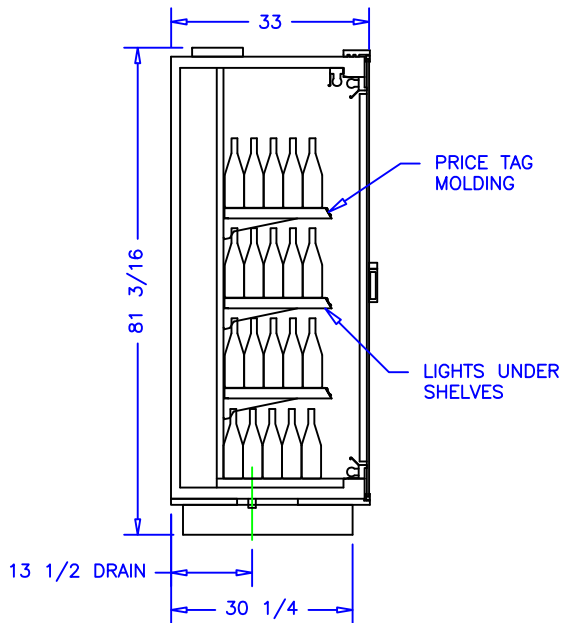
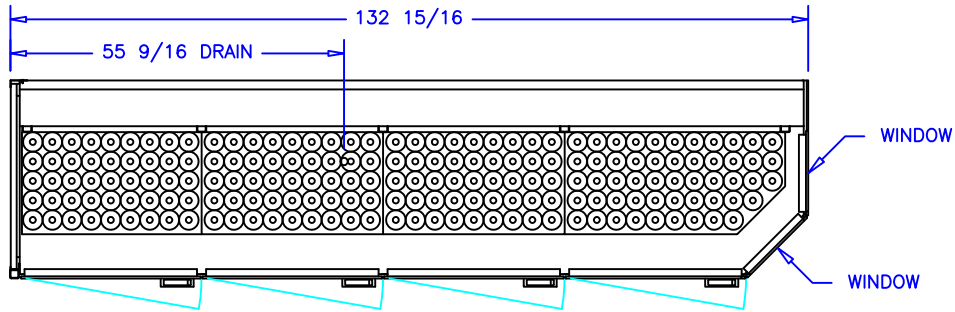

TOTAL BOTTLES FOR CASE: 748



NOTES:

1. OPTIONS NOT SHOWN ON DRAWING SHOULD BE LISTED IN WRITTEN PROPOSAL AND LISTED ON PURCHASE ORDER.
2. ELEC. CONNECTION: 115V/230V, 4x4 SUPPLY BOX AS NEEDED.
3. EXPANSION VALVES: SPORLAN "Q" SERIES STANDARD UNLESS OTHERWISE SPECIFIED.
4. DEFROST CONTROL: REMOTE CASES (N/A, DIGITAL CASE CONTROLLERS AVAILABLE), OPTIONAL CONDENSING UNIT (DIGITAL CASE CONTROLLER).
5. THERMOSTATS & LIQUID LINE SOLENOID VALVES: OPTIONAL.
6. DRAIN: 1 1/2 INCH PVC.
7. SPECIFICATIONS SUBJECT TO CHANGE WITHOUT NOTICE.

AUTHORIZATION (PRINT):	DATE:					 börger systems	DRAWN BY: D HUNT
							CHECKED BY:
						4DR WINE	
		DATE	REV.	DIM:	INCH		DRAWING NUMBER
		REVISION		TOL:			P6308