

CASE SPECIFICATIONS:

REFRIGERATION:

LOAD: 5,320 BTU/hr
 SUCTION TEMP: 30°F
 SUCTION LINE: 5/8IN ODS
 LIQUID LINE: 3/8IN ODS

ELECTRICAL 115V, 60HZ, 1PH
 EVAP. FANS: 0.6A
 LIGHT BALLASTS: 2.40A
 TOTAL: 3.0A
 MCA: 15.0A

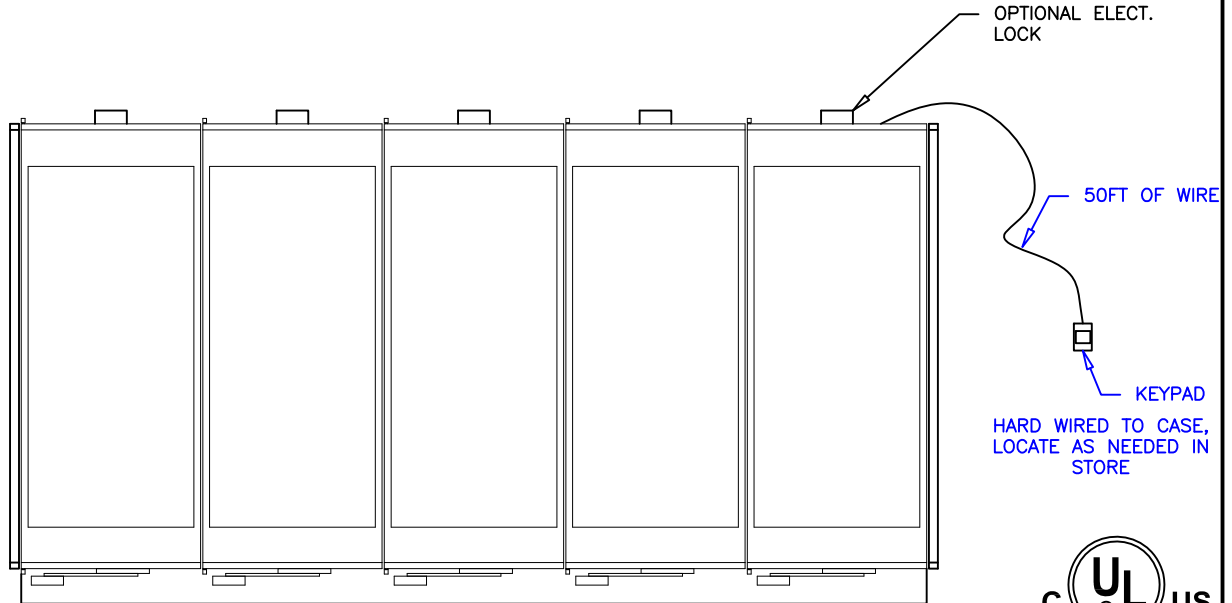
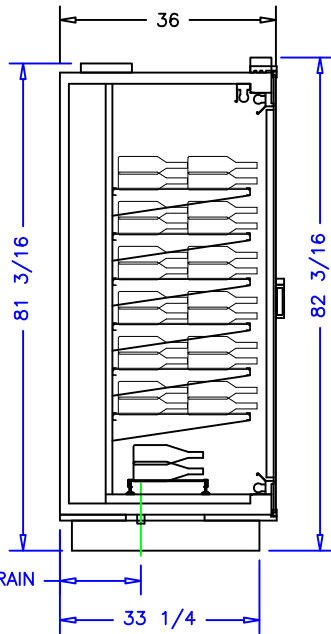
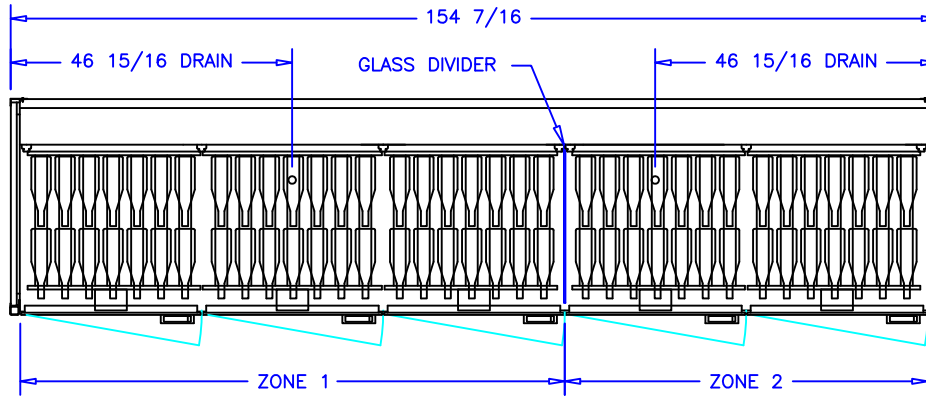

37X1
 COMMERCIAL REFRIGERATOR
 LESS CONDENSING UNIT

NOTES:

1. OPTIONS NOT SHOWN ON DRAWING SHOULD BE LISTED IN WRITTEN PROPOSAL AND LISTED ON PURCHASE ORDER.
2. ELEC. CONNECTION: 115V/230V, 4x4 SUPPLY BOX AS NEEDED.
3. EXPANSION VALVES: SPORLAN "Q" SERIES STANDARD UNLESS OTHERWISE SPECIFIED.
4. DEFROST CONTROL: REMOTE CASES (N/A, DIGITAL CASE CONTROLLERS AVAILABLE), OPTIONAL CONDENSING UNIT (DIGITAL CASE CONTROLLER).
5. THERMOSTATS & LIQUID LINE SOLENOID VALVES: OPTIONAL.
6. DRAIN: 1 1/2 INCH PVC.
7. SPECIFICATIONS SUBJECT TO CHANGE WITHOUT NOTICE.

| | | | | | |
|------------------------|-------|----------|------|----------------|------------------|
| AUTHORIZATION (PRINT): | DATE: | | | SCALE: 1:24 | DRAWN BY: D HUNT |
| | | | | DATE: 5-16-11 | CHECKED BY: |
| | | 5DR WINE | | | |
| DATE | REV. | DIM: | INCH | DRAWING NUMBER | |
| REVISION | | TOL: | | P6035 | |