

CASE SPECIFICATIONS:

REFRIGERATION:

LOAD: 6,900 BTU/hr  
 COIL TEMP: 30°F  
 SUCTION STUB: 5/8IN ODS  
 LIQUID STUB: 3/8IN ODS

ELECTRICAL 115V, 60HZ, 1PH  
 EVAP. FANS: 0.6A  
 LIGHTS: 7.2A  
 CONDENSATE PUMP: 1.0A  
 CONDENSATE PAN: 3.0A  
 TOTAL: 11.8A  
 MCA: 15.0A

OPTIONAL ELECTRICAL 208V, 60HZ, 1PH  
 3/4 HP COND. UNIT: 6.1A  
 TOTAL: 6.1A  
 MCA: 8.8A

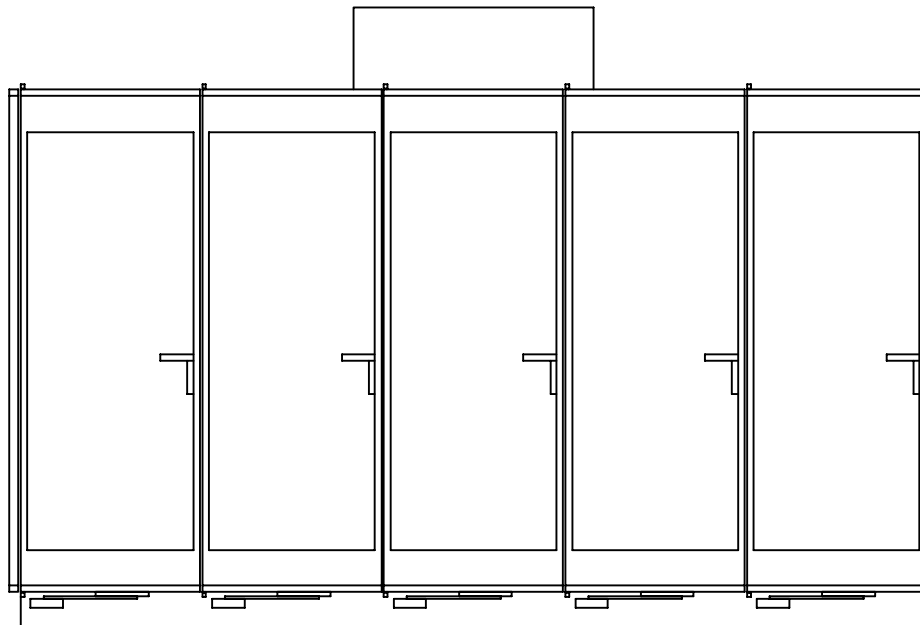
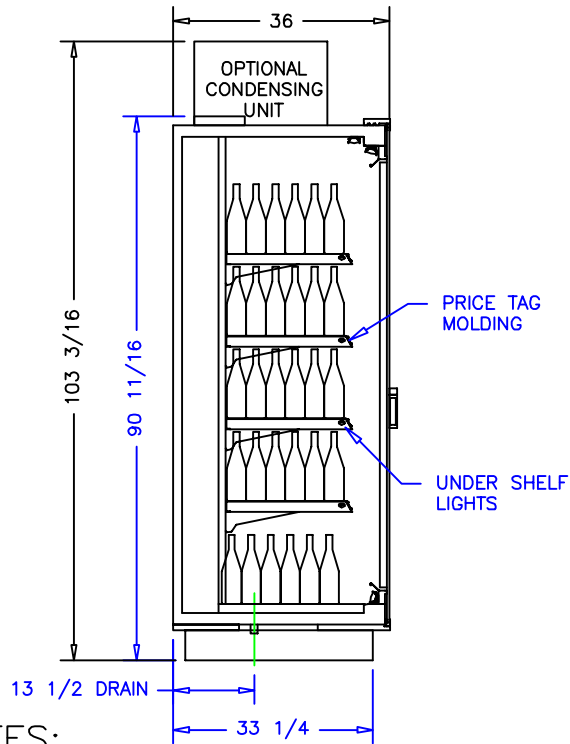
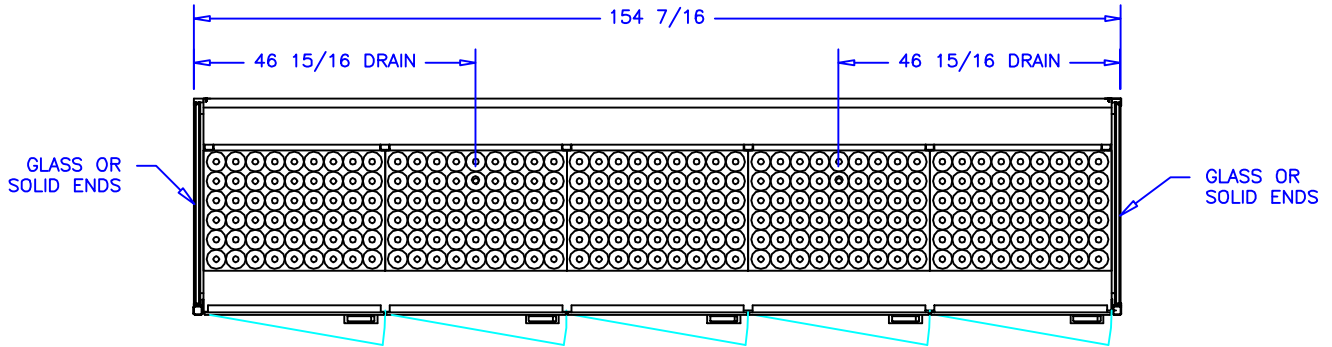

NOTES:

1. OPTIONS NOT SHOWN ON DRAWING SHOULD BE LISTED IN WRITTEN PROPOSAL AND LISTED ON PURCHASE ORDER.
2. ELEC. CONNECTION: 115V/230V, 4x4 SUPPLY BOX AS NEEDED.
3. EXPANSION VALVES: SPORLAN "Q" SERIES STANDARD UNLESS OTHERWISE SPECIFIED.
4. DEFROST CONTROL: REMOTE CASES (N/A, DIGITAL CASE CONTROLLERS AVAILABLE), OPTIONAL CONDENSING UNIT (DIGITAL CASE CONTROLLER).
5. THERMOSTATS & LIQUID LINE SOLENOID VALVES: OPTIONAL.
6. DRAIN: 1 1/2 INCH PVC.
7. SPECIFICATIONS SUBJECT TO CHANGE WITHOUT NOTICE.

AUTHORIZATION (PRINT):		DATE:		 <b>börgeren systems</b>		SCALE: 1:32		DRAWN BY: D HUNT	
						DATE: 8-10-09		CHECKED BY:	
		2-12-15 DRH		5DR WINE TALL					
		7-14-11 DRH							
		4-28-10 DRH							
DATE		REV.		DIM.		INCH		DRAWING NUMBER	
REVISION		TOL:						P5687	