

DOORED CASE SPECIFICATIONS:

REFRIGERATION
 LOAD: 4,025 BTU/hr
 SUCTION TEMP: 25° F
 LIQUID LINE: 3/8IN ODS
 SUCTION LINE: 5/8IN ODS

ELECTRICAL 115VAC, 60HZ, 1PH.
 EVAP. FANS: .30A
 LED LIGHTS: 2.4A
 TOTAL: 2.7A
 MCA: 15.0A

OPEN CASE SPECIFICATIONS:

REFRIGERATION
 LOAD: 10,800 BTU/hr
 SUCTION TEMP: 25°
 LIQUID LINE: 3/8IN ODS
 SUCTION LINE: 5/8IN ODS

ELECTRICAL 115VAC, 60HZ, 1PH.
 EVAP. FANS: 1.2A
 LED LIGHTS: 2.4A
 TOTAL: 3.6A
 MCA: 15.0A

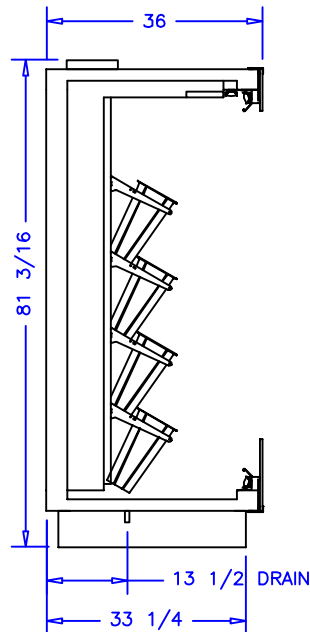
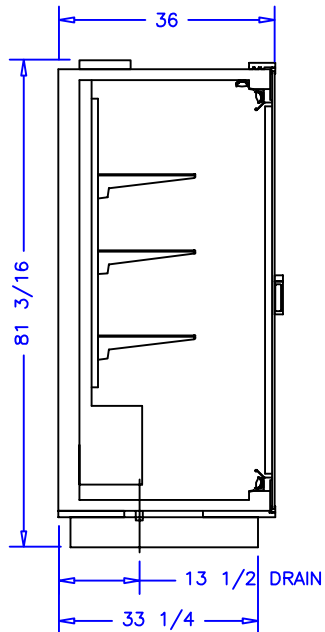

NOTES:

1. OPTIONS NOT SHOWN ON DRAWING SHOULD BE LISTED IN WRITTEN PROPOSAL AND LISTED ON PURCHASE ORDER.
2. ELEC. CONNECTION: 115V/230V, 4x4 SUPPLY BOX AS NEEDED.
3. EXPANSION VALVES: SPORLAN "Q" SERIES STANDARD UNLESS OTHERWISE SPECIFIED.
4. DEFROST CONTROL: REMOTE CASES (N/A, DIGITAL CASE CONTROLLERS AVAILABLE), OPTIONAL CONDENSING UNIT (DIGITAL CASE CONTROLLER).
5. THERMOSTATS & LIQUID LINE SOLENOID VALVES: OPTIONAL.
6. DRAIN: 1 1/2 INCH PVC.
7. SPECIFICATIONS SUBJECT TO CHANGE WITHOUT NOTICE.



AUTHORIZATION (PRINT):		DATE:		 börgeren systems	
SIGNATURE:					
				DATE: 11-11-08	CHECKED BY:
				3DR 8FT RIGHT	
DATE	REV.	DWG.	INCH	DRAWING NUMBER	
REVISION	TOL:			P5522	