

**DOORED CASE SPECIFICATIONS:**

REFRIGERATION:  
 LOAD: 4,025 BTU/hr  
 SUCTION TEMP: 20°F  
 SUCTION LINE: 5/8" ODS  
 LIQUID LINE: 3/8" ODS

ELECTRICAL 115V, 60HZ, 1PH  
 EVAP. FANS: 0.13A  
 LIGHT BALLASTS: 1.48A  
 TOTAL: 1.61A

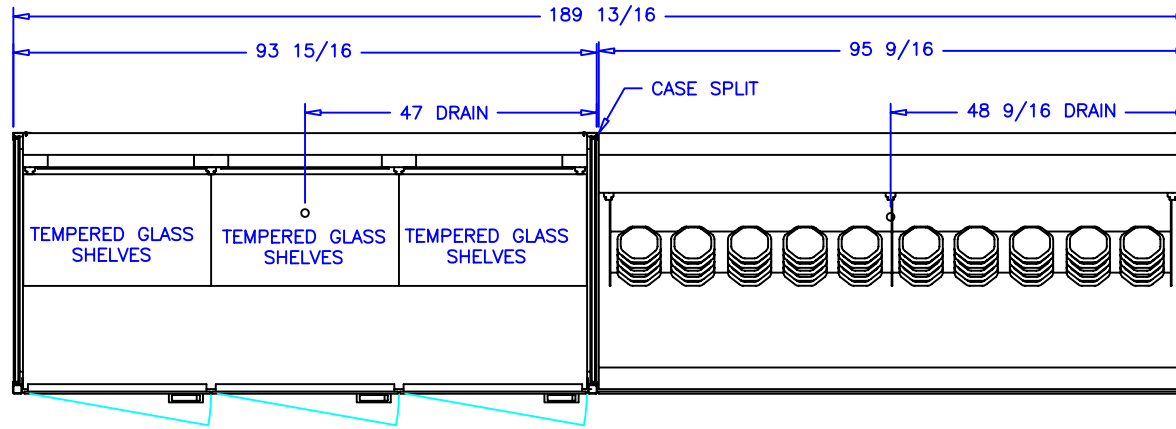

**OPEN CASE SPECIFICATIONS:**

REFRIGERATION:  
 LOAD: 10,800 BTU/hr  
 SUCTION TEMP: 20°F  
 SUCTION LINE: 5/8" ODS  
 LIQUID LINE: 3/8" ODS

ELECTRICAL 115V, 60HZ, 1PH  
 EVAP. FANS: 0.52A  
 LIGHT BALLASTS: 1.48A  
 FRESH WATER SYSTEM: 5.5A  
 TOTAL: 7.50A

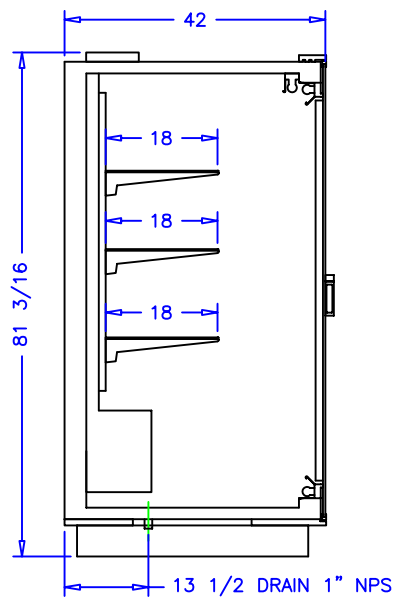
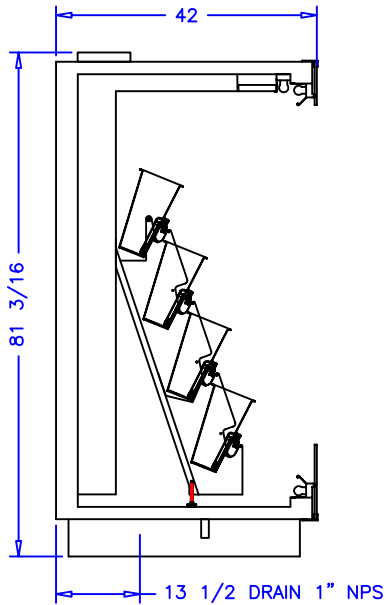

FLOOR DRAIN IS  
 REQUIRED

**NOTES:**

1. OPTIONS NOT SHOWN ON DRAWING SHOULD BE STATED IN WRITTEN PROPOSAL AND LISTED ON PURCHASE ORDER.
2. ELEC. CONNECTION: 115V/230V, 4X4 SUPPLY BOX AS NEEDED.
3. EXPANSION VALVES: SPORLAN "Q" SERIES STANDARD UNLESS OTHERWISE SPECIFIED.
4. DEFROST CONTROL: REMOTE CASES (N/A, DIGITAL CASE CONTROLLERS AVAILABLE), OPTIONAL CONDENSING UNIT (DIGITAL CASE CONTROLLER).
5. THERMOSTATS & LIQUID LINE SOLENOID VALVES: OPTIONAL.
6. DRAIN: 1 INCH NATIONAL PIPE STRAIGHT THREAD.
7. SPECIFICATIONS SUBJECT TO CHANGE WITHOUT NOTICE.

		 <b>börger systems</b>	
		SCALE: 1:20	DRAWN BY: D HUNT
		DATE: 4-15-04	CHECKED BY: NAME
<b>3 DOOR &amp; 8FT DF FWE</b>			
DATE	REV.	DIM: INCH	DRAWING NUMBER
REVISION		TOL: ±1/32	P4424B