

OPEN CASE SPECIFICATIONS:

REFRIGERATION:

LOAD: 10,800 BTU/hr
 SUCTION TEMP: 20°F
 SUCTION LINE: 5/8" ODS
 LIQUID LINE: 3/8" ODS

ELECTRICAL 115V, 60HZ, 1PH
 EVAP. FANS: 0.52A
 LIGHT BALLASTS: 1.48A
 FRESH WATER SYSTEM: 5.5A
 TOTAL: 7.50A

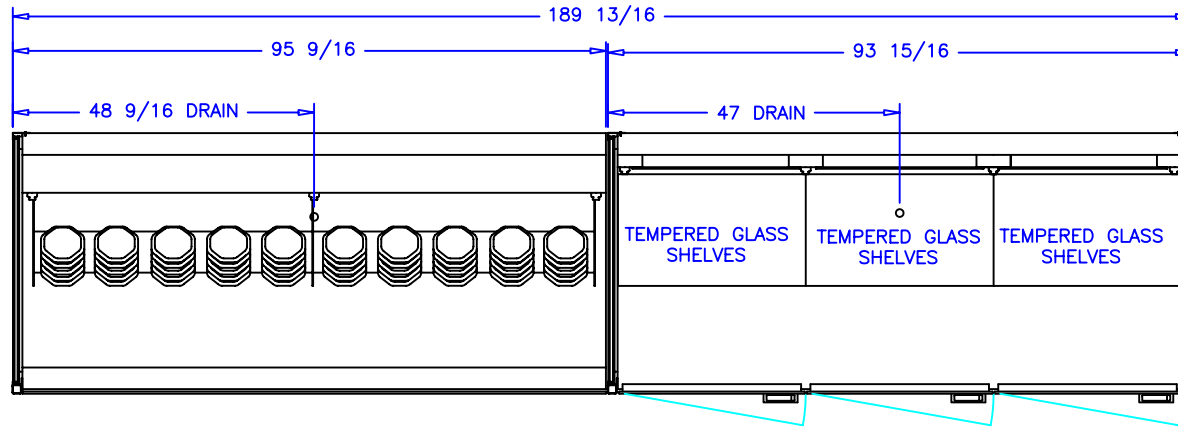

DOORED CASE SPECIFICATIONS:

REFRIGERATION:

LOAD: 4,025 BTU/hr
 SUCTION TEMP: 20°F
 SUCTION LINE: 5/8" ODS
 LIQUID LINE: 3/8" ODS

ELECTRICAL 115V, 60HZ, 1PH
 EVAP. FANS: 0.13A
 LIGHT BALLASTS: 1.48A
 TOTAL: 1.61A

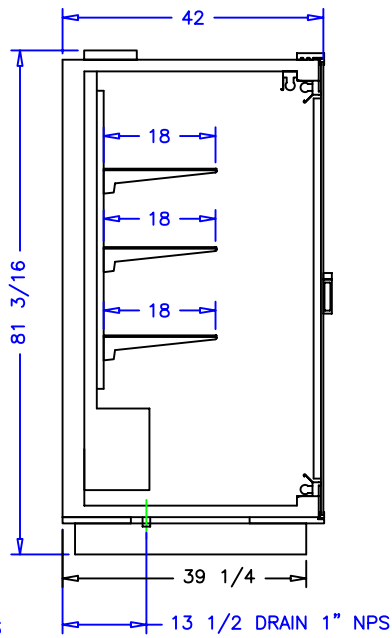
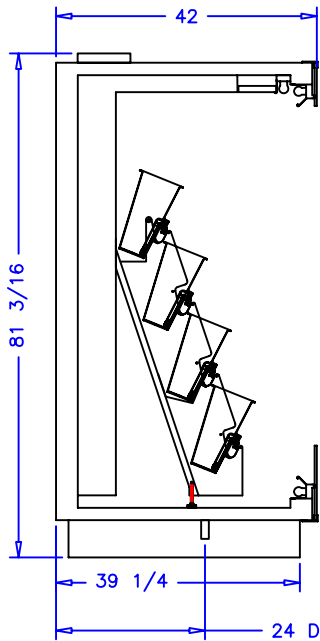

FLOOR DRAIN IS REQUIRED

NOTES:

1. OPTIONS NOT SHOWN ON DRAWING SHOULD BE STATED IN WRITTEN PROPOSAL AND LISTED ON PURCHASE ORDER.
2. ELEC. CONNECTION: 115V/230V, 4X4 SUPPLY BOX AS NEEDED.
3. EXPANSION VALVES: SPORLAN "Q" SERIES STANDARD UNLESS OTHERWISE SPECIFIED.
4. DEFROST CONTROL: REMOTE CASES (N/A, DIGITAL CASE CONTROLLERS AVAILABLE), OPTIONAL CONDENSING UNIT (DIGITAL CASE CONTROLLER).
5. THERMOSTATS & LIQUID LINE SOLENOID VALVES: OPTIONAL.
6. DRAIN: 1 INCH NATIONAL PIPE STRAIGHT THREAD.
7. SPECIFICATIONS SUBJECT TO CHANGE WITHOUT NOTICE.

		 börgeren systems	
		SCALE: 1:20	DRAWN BY: D HUNT
		DATE: 3-25-04	CHECKED BY: NAME
3 DOOR & 8FT DF FWE			
DATE	REV.	DM: INCH	DRAWING NUMBER
REVISION		TOL: ±1/32	P4403B