

CASE SPECIFICATIONS:

REFRIGERATION
 LOAD: 8,750 BTU/hr
 COIL TEMP: 25° F
 LIQUID STUB: 3/8IN ODS
 SUCTION STUB: 5/8IN ODS

ELECTRICAL 115VAC, 60HZ, 1PH.
 EVAP. FANS: .90A
 LIGHTS: 2.4A
 FRESH WATER SYSTEM: 5.0A
 TOTAL: 8.3A
 MCA: 15.0A



NOTES:

1. OPTIONS NOT SHOWN ON DRAWING SHOULD BE LISTED IN WRITTEN PROPOSAL AND LISTED ON PURCHASE ORDER.
2. ELEC. CONNECTION: 115V/230V, 4x4 SUPPLY BOX AS NEEDED.
3. EXPANSION VALVES: SPORLAN "Q" SERIES STANDARD UNLESS OTHERWISE SPECIFIED.
4. DEFROST CONTROL: REMOTE CASES (N/A, DIGITAL CASE CONTROLLERS AVAILABLE), OPTIONAL CONDENSING UNIT (DIGITAL CASE CONTROLLER).
5. THERMOSTATS & LIQUID LINE SOLENOID VALVES: OPTIONAL.
6. DRAIN: 1 1/2 INCH PVC.
7. SPECIFICATIONS SUBJECT TO CHANGE WITHOUT NOTICE.

FLOOR DRAIN MUST BE PROVIDED FOR THIS CASE

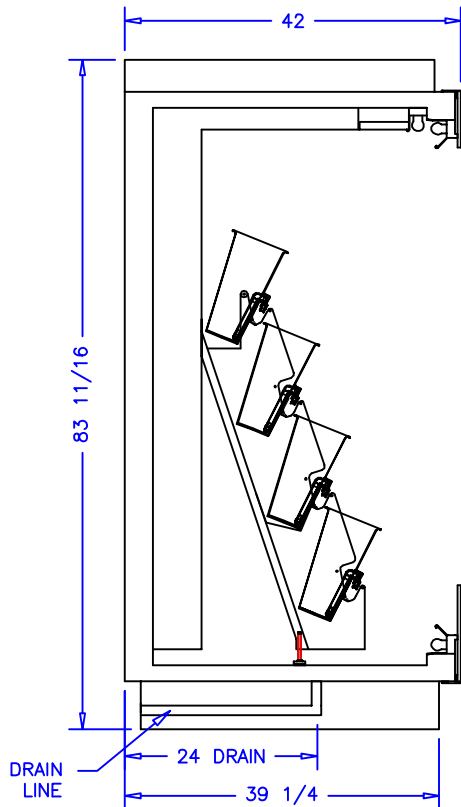

AUTHORIZATION (PRINT):		DATE:		 börger systems		SCALE: 1:24		DRAWN BY: D HUNT	
SIGNATURE:						DATE: 5-28-02		CHECKED BY:	
7-10-14 DRH		5-4-12 DRH		6FT OPEN FWE					
DATE		REV.		DIM:		INCH		DRAWING NUMBER	
REVISION		TOL:						P4147	