

CASE SPECIFICATIONS:

REFRIGERATION
 LOAD: 4,100 BTU/hr
 COIL TEMP: 25° F
 LIQUID STUB: 3/8IN ODS
 SUCTION STUB: 3/8IN ODS

ELECTRICAL 115VAC, 60HZ, 1PH.
 EVAP. FANS: .30A
 LIGHTS: 1.2A
 TOTAL: 1.5A
 MCA: 15.0A

OVALS & CIRCLE, TOP THAT SHOWS IS
 SOLID SURFACE MATERIAL

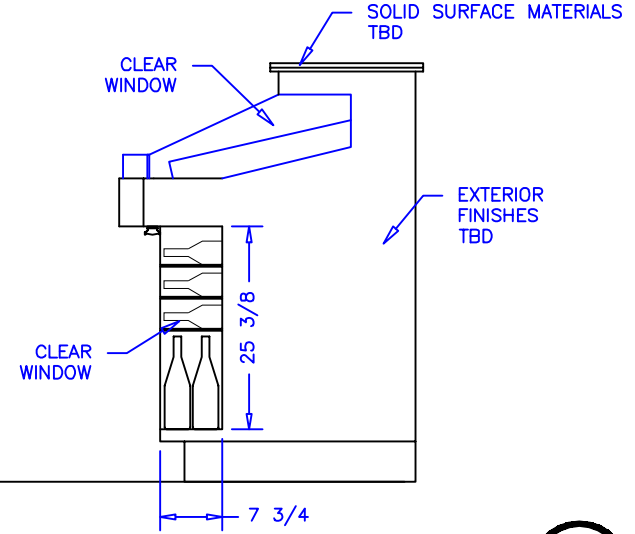
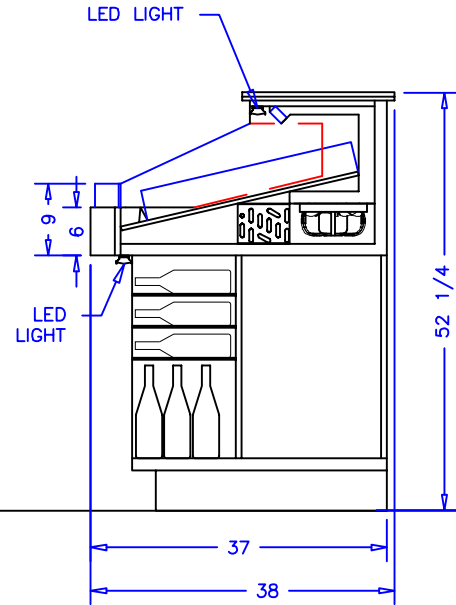
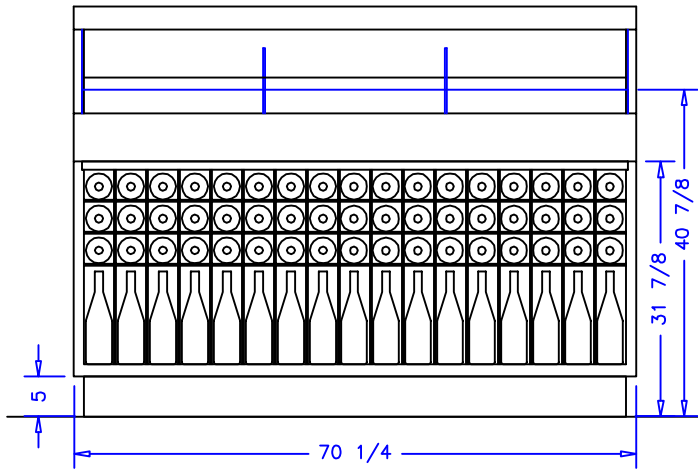

NOTES:

1. OPTIONS NOT SHOWN ON DRAWING SHOULD BE LISTED IN WRITTEN PROPOSAL AND LISTED ON PURCHASE ORDER.
2. ELEC. CONNECTION: 115V/230V, 4x4 SUPPLY BOX AS NEEDED.
3. EXPANSION VALVES: SPORLAN "Q" SERIES STANDARD UNLESS OTHERWISE SPECIFIED.
4. DEFROST CONTROL: REMOTE CASES (N/A, DIGITAL CASE CONTROLLERS AVAILABLE), OPTIONAL CONDENSING UNIT (DIGITAL CASE CONTROLLER).
5. THERMOSTATS & LIQUID LINE SOLENOID VALVES: OPTIONAL.
6. SPECIFICATIONS SUBJECT TO CHANGE WITHOUT NOTICE.



| | | | | | | | | | |
|------------------------|--|-------|--|-------------------------------------------------------------------------------------------------------------|--|---------------|--|------------------|--|
| AUTHORIZATION (PRINT): | | DATE: | |  börger systems | | SCALE: 1:24 | | DRAWN BY: D HUNT | |
| SIGNATURE: | | | | | | DATE: 4-24-14 | | CHECKED BY: | |
| 6FT CHEESE AND WINE | | | | | | | | | |
| DATE | | REV. | | DIM. | | INCH | | DRAWING NUMBER | |
| REVISION | | TOL: | | | | | | P6652 | |