

(4) GFCI OUTLETS ABOVE BACK SPLASH

(3) 23 x 32 POLY CUTTING BOARDS FIT INTO STAINLESS TRAY TOP OF CABINET

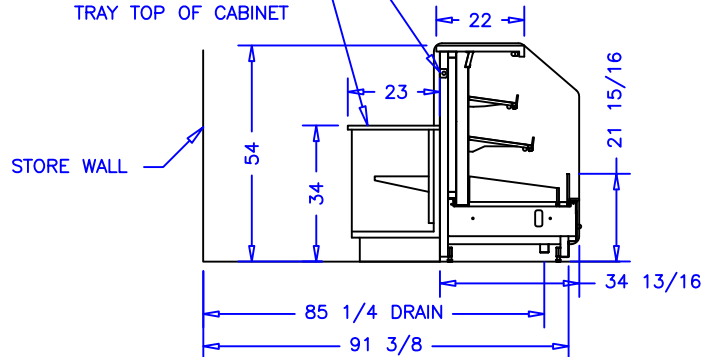

CASE SPECIFICATIONS:

REFRIGERATION
 LOAD: 15,900 BTU/hr
 COIL TEMP: 22° F
 LIQUID STUBS: 3/8IN ODS
 SUCTION STUBS: 5/8IN ODS

ELECTRICAL 115VAC, 60HZ, 1PH.
 EVAP. FANS: 3.0A
 LIGHTS: 3.6A
 TOTAL: 6.6A
 MCA: 15.0A

NOTES:

1. OPTIONS NOT SHOWN ON DRAWING SHOULD BE LISTED IN WRITTEN PROPOSAL AND LISTED ON PURCHASE ORDER.
2. ELEC. CONNECTION: 115V/230V, 4x4 SUPPLY BOX AS NEEDED.
3. EXPANSION VALVES: SPORLAN "Q" SERIES STANDARD UNLESS OTHERWISE SPECIFIED.
4. DEFROST CONTROL: REMOTE CASES (N/A, DIGITAL CASE CONTROLLERS AVAILABLE), OPTIONAL CONDENSING UNIT (DIGITAL CASE CONTROLLER).
5. THERMOSTATS & LIQUID LINE SOLENOID VALVES: OPTIONAL.
6. DRAIN: 1 1/2 INCH PVC.
7. SPECIFICATIONS SUBJECT TO CHANGE WITHOUT NOTICE.



AUTHORIZATION (PRINT):		DATE:				DRAWN BY: D HUNT		
SIGNATURE:						CHECKED BY:		
4-29-13	DRH	4-22-13	DRH	SCALE: 1:48				
4-18-13	DRH	DATE: 4-4-13						
4-12-13	DRH	PRODUCE PREP W10W					DRAWING NUMBER	
4-11-13	DRH						P6398	
DATE	REV.	DIM:	INCH					
REVISION	TOL:							