

(6) GFCI OUTLETS ABOVE BACK SPLASH

(3) 30 x 32 POLY CUTTING BOARDS FIT INTO STAINLESS TRAY TOP OF CABINET

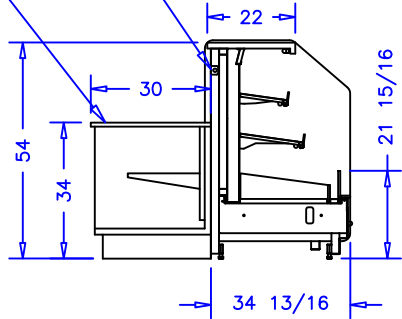

CASE SPECIFICATIONS:

REFRIGERATION
 LOAD: 23,000 BTU/hr
 COIL TEMP: 22° F
 LIQUID STUBS: 3/8IN ODS
 SUCTION STUBS: 5/8IN ODS

ELECTRICAL 115VAC, 60HZ, 1PH.
 EVAP. FANS: 4.2A
 LIGHTS: 4.8A
 TOTAL: 9.0A
 MCA: 15.0A

NOTES:

1. OPTIONS NOT SHOWN ON DRAWING SHOULD BE LISTED IN WRITTEN PROPOSAL AND LISTED ON PURCHASE ORDER.
2. ELEC. CONNECTION: 115V/230V, 4x4 SUPPLY BOX AS NEEDED.
3. EXPANSION VALVES: SPORLAN "Q" SERIES STANDARD UNLESS OTHERWISE SPECIFIED.
4. DEFROST CONTROL: REMOTE CASES (N/A, DIGITAL CASE CONTROLLERS AVAILABLE), OPTIONAL CONDENSING UNIT (DIGITAL CASE CONTROLLER).
5. THERMOSTATS & LIQUID LINE SOLENOID VALVES: OPTIONAL.
6. DRAIN: 1 1/2 INCH PVC.
7. SPECIFICATIONS SUBJECT TO CHANGE WITHOUT NOTICE.



AUTHORIZATION (PRINT):		DATE:				SCALE: 1:48		DRAWN BY: D HUNT	
SIGNATURE:						DATE: 4-1-13		CHECKED BY:	
				4-11-13 DRH		PRODUCE PREP 4W10W4			
DATE		REV.		DIM: INCH		DRAWING NUMBER		P6390	
REVISION		TOL:							