

DLI100 6' REMOTE GOURMET SANDWICH SPECIFICATIONS:

REFRIGERATION  
 LOAD: 1,500 BTU/hr  
 COIL TEMP: 25° F  
 LIQUID STUBS: 3/8IN ODS  
 SUCTION STUBS: 5/8IN ODS

ELECTRICAL 115VAC, 60HZ, 1PH.  
 EVAP. FANS: .52A  
 TOTAL: .52A

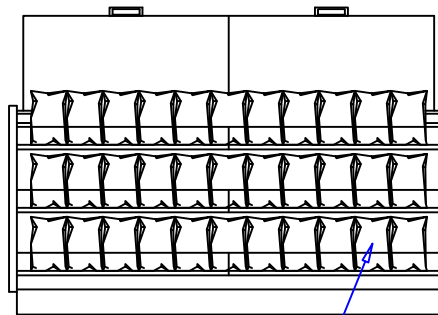
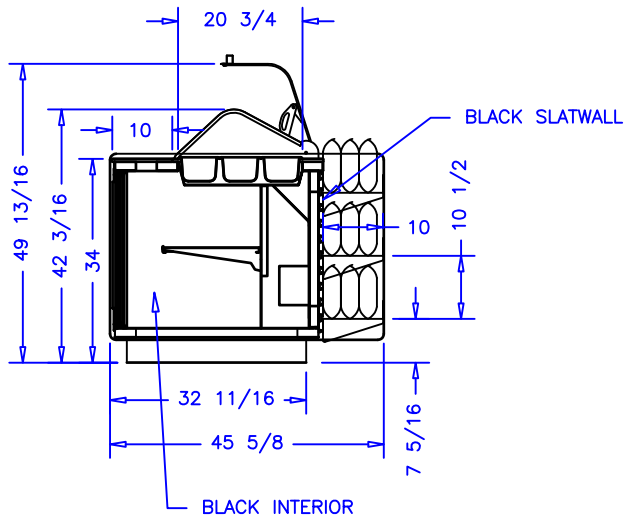

FRONT  
 99 CHIP BAGS

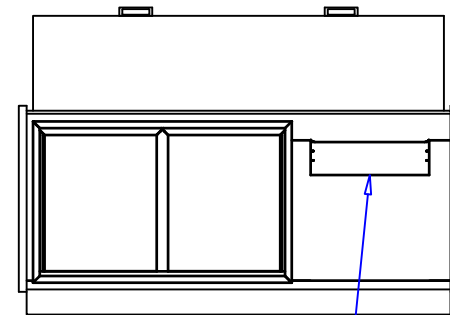

BACK  
 PAPER TRAY

NOTES:

1. OPTIONS NOT SHOWN ON DRAWING SHOULD BE LISTED IN WRITTEN PROPOSAL AND LISTED ON PURCHASE ORDER.
2. ELEC. CONNECTION: 115V/230V, 4x4 SUPPLY BOX AS NEEDED.
3. EXPANSION VALVES: SPORLAN "Q" SERIES STANDARD UNLESS OTHERWISE SPECIFIED.
4. DEFROST CONTROL: REMOTE CASES (N/A, DIGITAL CASE CONTROLLERS AVAILABLE), OPTIONAL CONDENSING UNIT (DIGITAL CASE CONTROLLER).
5. THERMOSTATS & LIQUID LINE SOLENOID VALVES: OPTIONAL.
6. DRAIN: 1 1/2 INCH PVC.
7. SPECIFICATIONS SUBJECT TO CHANGE WITHOUT NOTICE.



AUTHORIZATION (PRINT):		DATE:		 <b>börgeren systems</b>		SCALE: 1:24		DRAWN BY: DRH	
SIGNATURE:						DATE: 8-3-12		CHECKED BY:	
				9-17-12 DRH		6' GOURMET W/CHIP SHELVES			
DATE		REV.		DIM: INCH		DRAWING NUMBER		P6262	
REVISION		TOL:							