

CASE SPECIFICATIONS:

REFRIGERATION
 LOAD: 4,800 BTU/hr
 COIL TEMP: 25° F
 LIQUID STUB: 3/8IN ODS
 SUCTION STUB: 5/8IN ODS

ELECTRICAL 115VAC, 60HZ, 1PH.
 EVAP. FANS: .60A
 LIGHTS: 2.4A
 TOTAL: 3.0A
 MCA: 15.0A

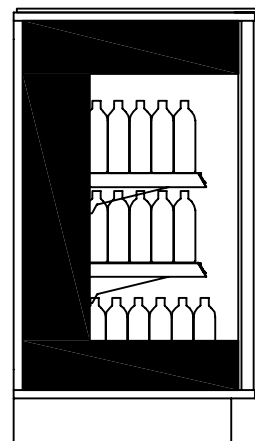
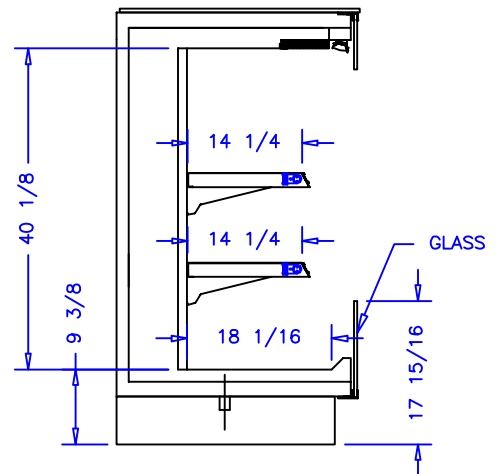
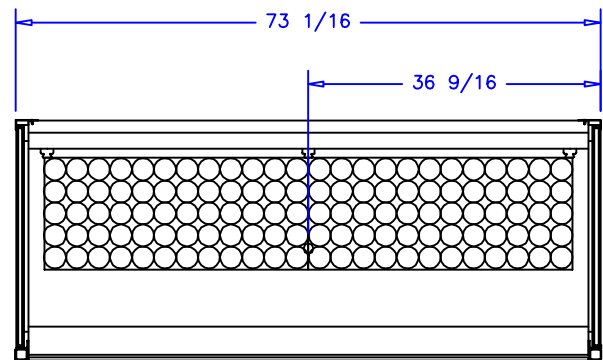

NOTES:

1. OPTIONS NOT SHOWN ON DRAWING SHOULD BE LISTED IN WRITTEN PROPOSAL AND LISTED ON PURCHASE ORDER.
2. ELEC. CONNECTION: 115V/230V, 4x4 SUPPLY BOX AS NEEDED.
3. EXPANSION VALVES: SPORLAN "Q" SERIES STANDARD UNLESS OTHERWISE SPECIFIED.
4. DEFROST CONTROL: REMOTE CASES (N/A, DIGITAL CASE CONTROLLERS AVAILABLE), OPTIONAL CONDENSING UNIT (DIGITAL CASE CONTROLLER).
5. THERMOSTATS & LIQUID LINE SOLENOID VALVES: OPTIONAL.
6. DRAIN: 1 1/2 INCH PVC.
7. SPECIFICATIONS SUBJECT TO CHANGE WITHOUT NOTICE.



AUTHORIZATION (PRINT):		DATE:		 börgeren systems	
SIGNATURE:					
				DATE: 5-27-14	CHECKED BY:
				6FT OPEN BEVERAGE	
		5-29-14 DRH		DRAWING NUMBER	
		DATE REV. DIM. INCH		P6664	
		REVISION TOL:			