

P=POWER SUPPLY BOX
 R=REFRIGERATION STUBS
 D=DRAIN STUB

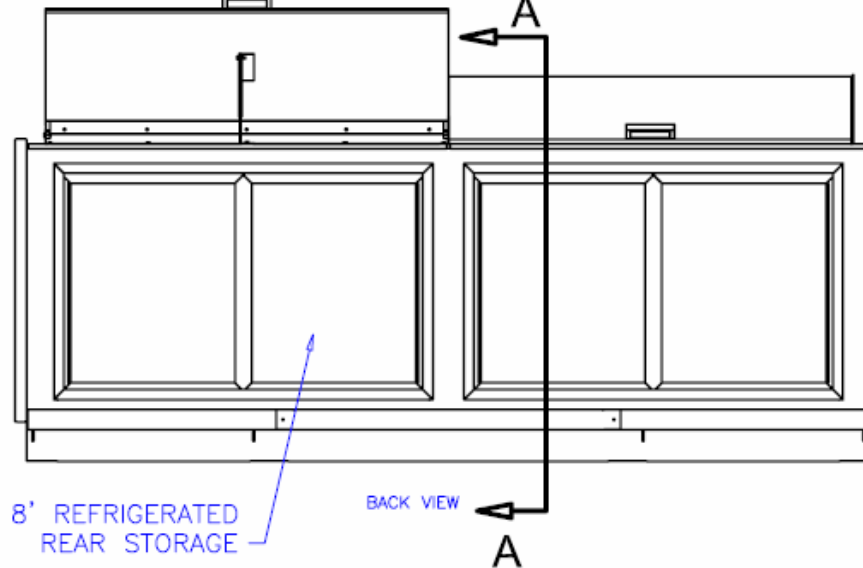
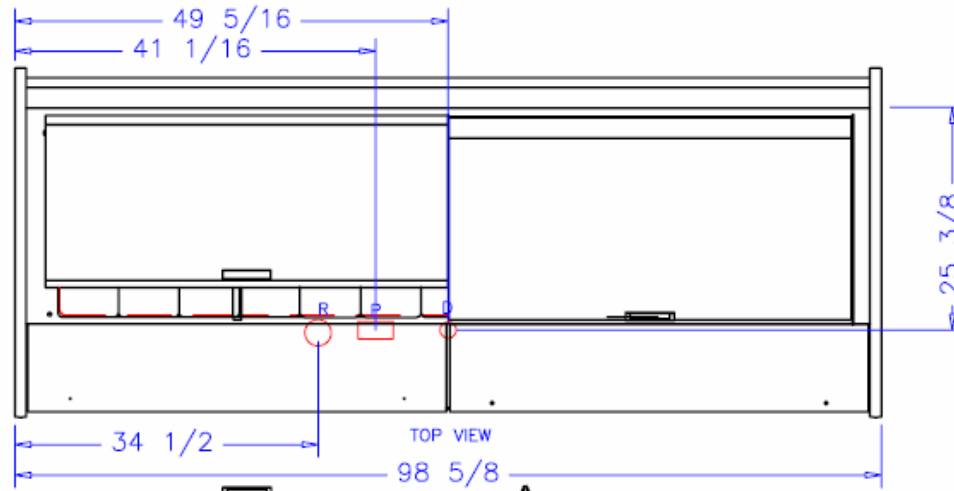
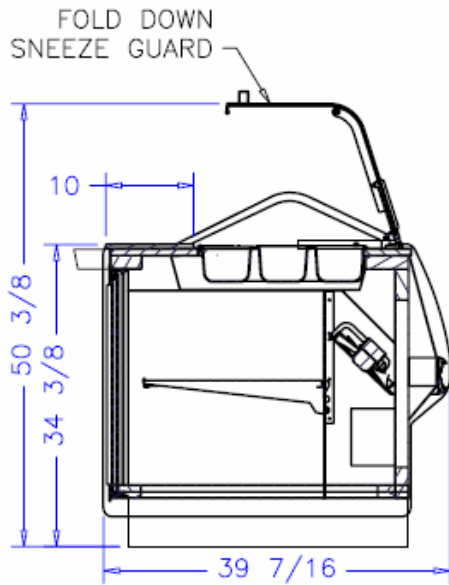

DLI100 8' REMOTE GOURMET SANDWICH SPECIFICATIONS:

REFRIGERATION
 LOAD: 2000 BTU/hr
 SUCTION TEMP: 20° F
 LIQUID LINE: 3/8IN ODS
 SUCTION LINE: 5/8IN ODS

ELECTRICAL 115VAC, 60HZ, 1PH.
 EVAP. FANS: 1.04A
 TOTAL: 1.04A



NOTES:

1. OPTIONS NOT SHOWN ON DRAWING SHOULD BE LISTED IN WRITTEN PROPOSAL AND LISTED ON PURCHASE ORDER.
2. ELEC. CONNECTION: 115V/230V, 4x4 SUPPLY BOX AS NEEDED.
3. EXPANSION VALVES: SPORLAN "Q" SERIES STANDARD UNLESS OTHERWISE SPECIFIED.
4. DEFROST CONTROL: REMOTE CASES (N/A, DIGITAL CASE CONTROLLERS AVAILABLE), OPTIONAL CONDENSING UNIT (DIGITAL CASE CONTROLLER).
5. THERMOSTATS & LIQUID LINE SOLENOID VALVES: OPTIONAL.
6. DRAIN: 1 1/2 INCH PVC.
7. SPECIFICATIONS SUBJECT TO CHANGE WITHOUT NOTICE.

AUTHORIZATION (PRINT):	DATE:			SCALE: 1:20	DRAWN BY: A. BESIC
SIGNATURE:				DATE: 11-13-08	CHECKED BY:
		8' GOURMET SANDWICH		BG8GSD	
DATE	REV	DN	INCH	DRAWING NUMBER	
REVISION	TOL			P5527A	