

CASE SPECIFICATIONS:

REFRIGERATION
 LOAD: 8,560 BTU/hr
 SUCTION TEMP: 20° F
 LIQUID LINE: 3/8IN ODS
 SUCTION LINE: 1/2IN ODS

ELECTRICAL 115V, 60HZ, 1PH.
 LIGHTS: 3.62A
 TOTAL: 3.62A
 MCA: 15.0A

ELECTRICAL 115V, 60HZ, 1PH.
 EVAP. FANS: 0.26A
 COND. PUMP: 1.0A
 TOTAL: 1.26A
 MCA: 15.0A

ELECTRICAL 230V, 60HZ, 1PH.
 1 1/2HP COND. UNIT: 10.9A
 CONDENSATE PAN: 14.4A
 TOTAL: 25.3A
 MCA: 30.9A

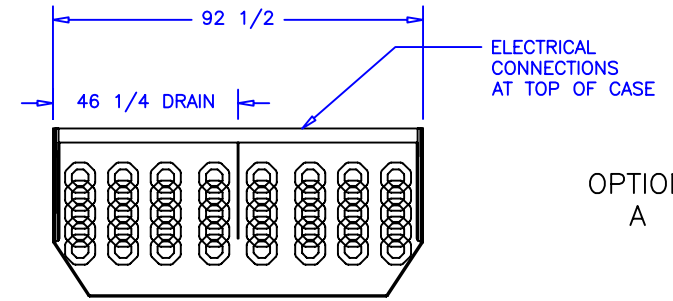
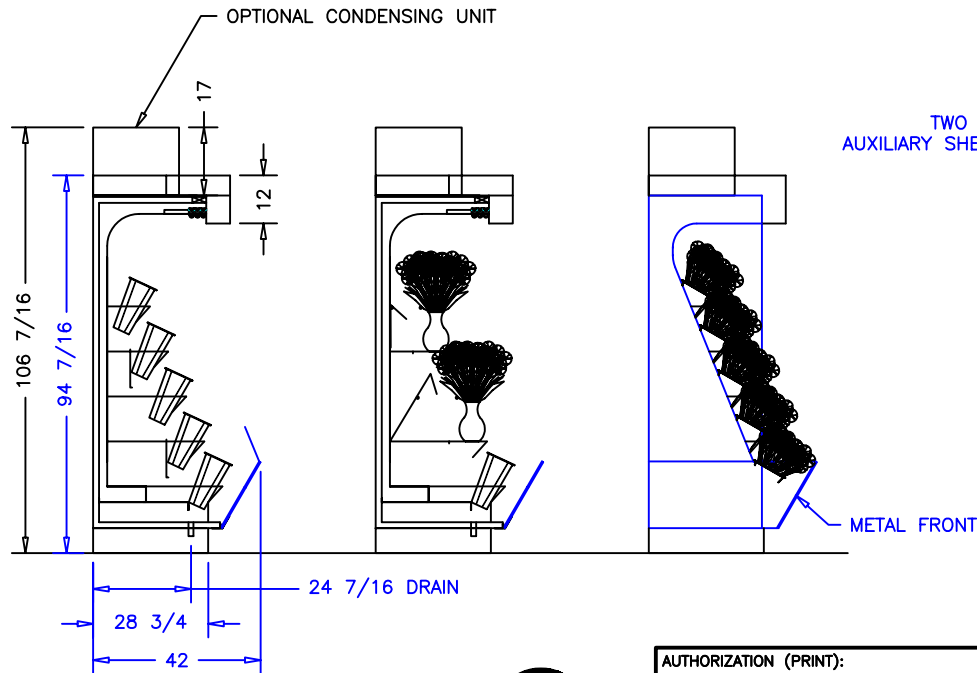

OPTION A

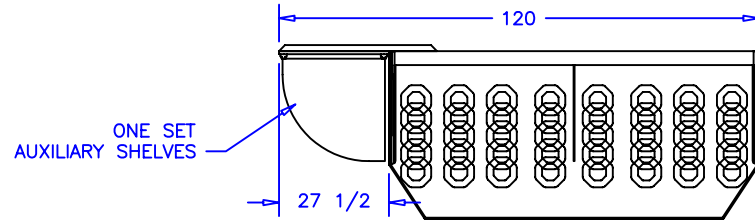

OPTION B

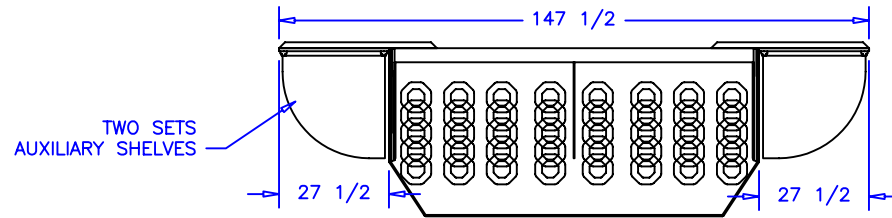

OPTION C

NOTES:

1. OPTIONS NOT SHOWN ON DRAWING SHOULD BE LISTED IN WRITTEN PROPOSAL AND LISTED ON PURCHASE ORDER.
2. ELEC. CONNECTION: 115V/230V, 4x4 SUPPLY BOX AS NEEDED.
3. EXPANSION VALVES: SPORLAN "Q" SERIES STANDARD UNLESS OTHERWISE SPECIFIED.
4. DEFROST CONTROL: REMOTE CASES (N/A, DIGITAL CASE CONTROLLERS AVAILABLE), OPTIONAL CONDENSING UNIT (DIGITAL CASE CONTROLLER).
5. THERMOSTATS & LIQUID LINE SOLENOID VALVES: OPTIONAL.
6. DRAIN: 1 1/2 INCH PVC.
7. SPECIFICATIONS SUBJECT TO CHANGE WITHOUT NOTICE.



AUTHORIZATION (PRINT):		DATE:		 börger systems		SCALE: 1:48		DRAWN BY: D HUNT	
SIGNATURE:						DATE: 7-21-06		CHECKED BY:	
				9-19-06 DRH		8FT FLOWER BASKET W/SHLV			
				DATE REV. DIM. INCH				DRAWING NUMBER	
				REVISION TOL:				P4895A	