

DLI100 8' REMOTE CAFE  
SPECIFICATIONS:

REFRIGERATION  
LOAD: 9,600 BTU/hr  
SUCTION TEMP: 20° F  
LIQUID LINE: 3/8IN ODS  
SUCTION LINE: 5/8IN ODS

ELECTRICAL 115VAC, 60HZ, 1PH.  
EVAP. FANS: 8.8A  
LIGHT BALLAST: 1.48A  
TOTAL: 10.28A  
MCA: 15.0A

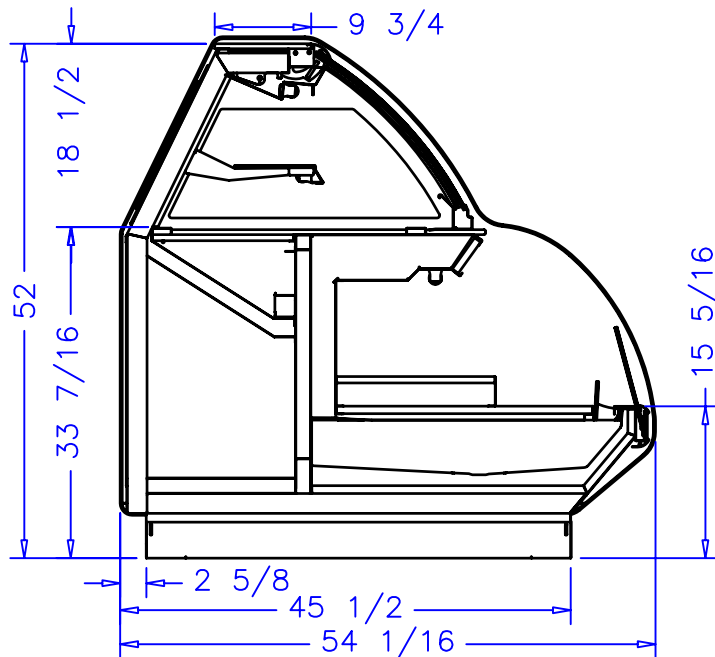

<h1>börger systems</h1>			
DATE: 07-18-06		CHECKED BY:	
<h2>8' REMOTE CAFE</h2>			
DATE	REV.	DIM: INCH	DRAWING NUMBER
REVISION		TOL: ±1/32	P4272A