

CASE SPECIFICATIONS:

REFRIGERATION

LOAD: 8,500 BTU/hr
 SUCTION TEMP: 20° F
 LIQUID LINE: 3/8IN ODS
 SUCTION LINE: 1/2IN ODS

ELECTRICAL 115V, 60HZ, 1PH.
 EVAP. FANS: 0.26A
 LIGHTS: 0.94A
 TOTAL: 1.20A

ELECTRICAL 230V, 60HZ, 1PH.
 CONDENSING UNIT: 9.9A
 CONDENSATE PAN: 6.5A
 TOTAL: 16.4A

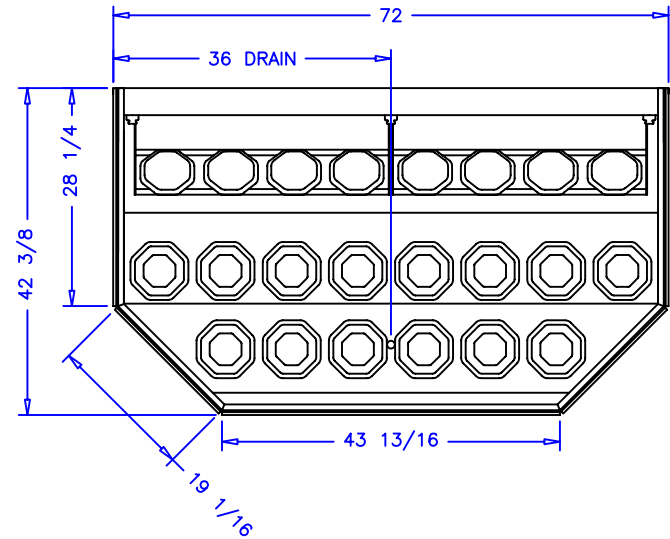
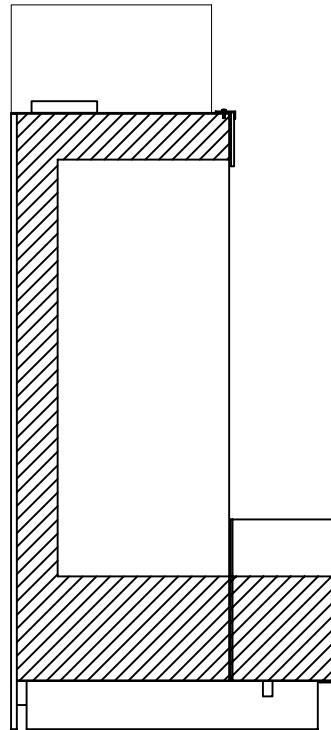
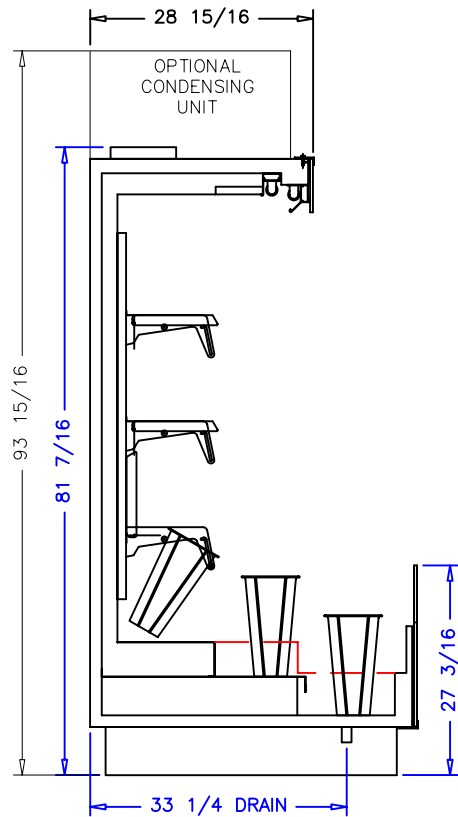

NOTES:

1. OPTIONS NOT SHOWN ON DRAWING SHOULD BE STATED IN WRITTEN PROPOSAL AND LISTED ON PURCHASE ORDER.
2. ELEC. CONNECTION: 115V/230V, 4X4 SUPPLY BOX AS NEEDED.
3. EXPANSION VALVES: SPORLAN "Q" SERIES STANDARD UNLESS OTHERWISE SPECIFIED.
4. DEFROST CONTROL: REMOTE CASES (N/A, DIGITAL CASE CONTROLLERS AVAILABLE), OPTIONAL CONDENSING UNIT (DIGITAL CASE CONTROLLER).
5. THERMOSTATS & LIQUID LINE SOLENOID VALVES: OPTIONAL.
6. DRAIN: 1 INCH NATIONAL PIPE STRAIGHT THREAD.
7. SPECIFICATIONS SUBJECT TO CHANGE WITHOUT NOTICE.

		 börger systems	
		SCALE: 1:24	DRAWN BY: D. HUNT
		DATE: 4-21-03	CHECKED BY:
9-17-03	DRH	6FT RFO	
DATE	REV.	DIM: INCH	DRAWING NUMBER
REVISION		TOL: ±1/32	P4128B