

DLI100 4' FOOD PREP HIGH
SPECIFICATIONS:

REFRIGERATION
LOAD: 3780 BTU/hr
SUCTION TEMP: 20° F
LIQUID LINE: 3/8IN ODS
SUCTION LINE: 5/8IN ODS

ELECTRICAL 115VAC, 60HZ, 1PH.
EVAP. FANS: 2.54A
LIGHT BALLAST: .75A
TOTAL: 3.29A
MCA: 15A

ELECTRICAL 208/230VAC,
60HZ, 1PH.
1/2HP COND. UNIT: 4.0A
CONDENSATE PAN: 7.2A
TOTAL: 11.2A
MCA: 12.8A

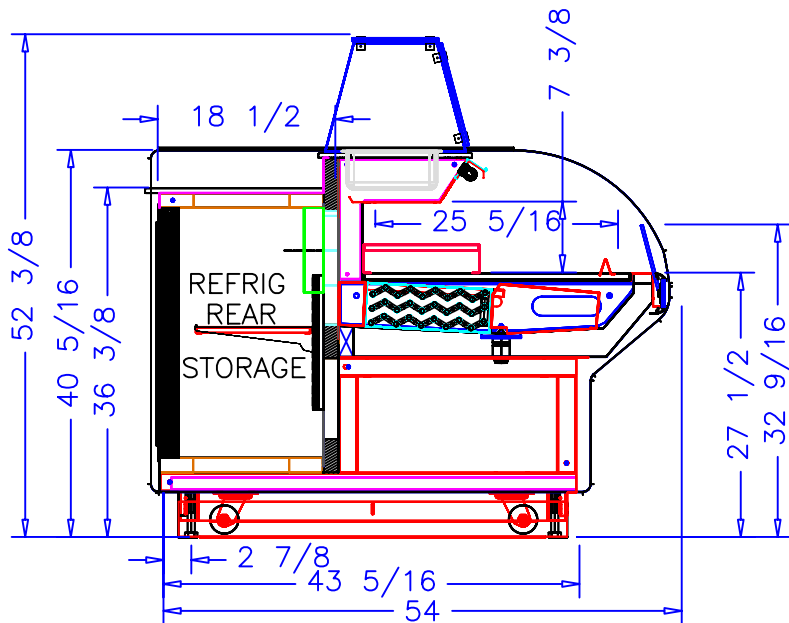

<h1>börger systems</h1>			
DATE: 06/23/04		CHECKED BY:	
4' FOOD PREP HIGH BG4PH			
DATE	REV.	DIM: INCH	DRAWING NUMBER
REVISION		TOL: ±1/32	P4255A