

CASE SPECIFICATIONS:

REFRIGERATION

LOAD: 9,250 BTU/hr
 SUCTION TEMP: 20-26° F
 LIQUID LINE: 3/8IN ODS
 SUCTION LINE: 5/8IN ODS

ELECTRICAL 115VAC, 60HZ, 1PH.
 EVAP. FANS: 1.0A
 LIGHT BALLAST: 2.22A
 TOTAL: 3.22A
 MCA: 15.0A

ELECTRICAL 230VAC, 60HZ, 1PH.
 (2) EVAP. PAN: 7.2A
 (2) 3/4HP COND. UNIT: 6.1A
 (4) WELLS 11QT HEATERS: 3.0A
 TOTAL: 38.6A
 MCA: 44.0A

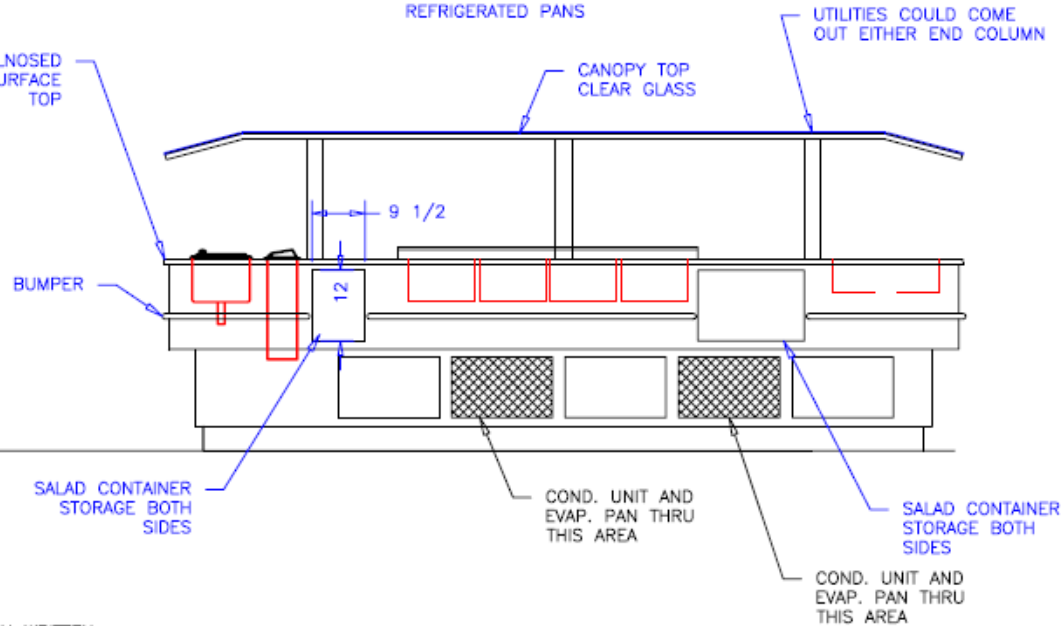
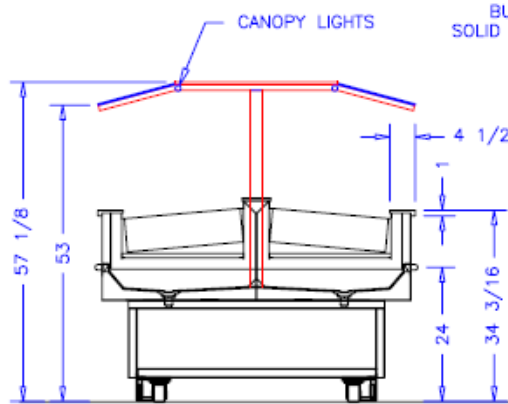
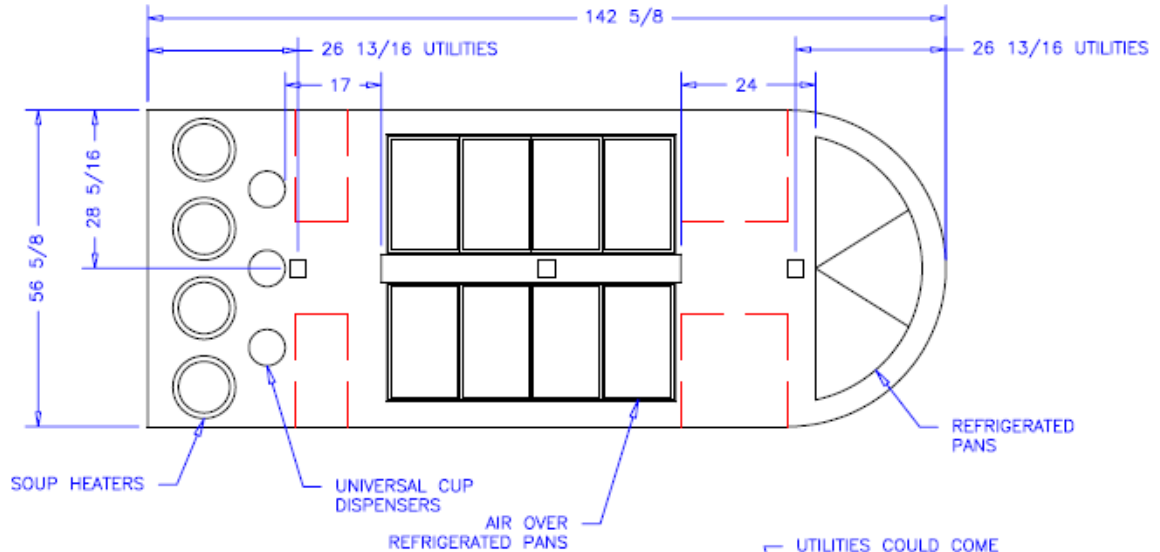

NOTES:

1. OPTIONS NOT SHOWN ON DRAWING SHOULD BE LISTED IN WRITTEN PROPOSAL AND LISTED ON PURCHASE ORDER.
2. ELEC. CONNECTION: 115V/230V, 4x4 SUPPLY BOX AS NEEDED.
3. EXPANSION VALVES: SPORLAN "Q" SERIES STANDARD UNLESS OTHERWISE SPECIFIED.
4. DEFROST CONTROL: REMOTE CASES (N/A, DIGITAL CASE CONTROLLERS AVAILABLE), OPTIONAL CONDENSING UNIT (DIGITAL CASE CONTROLLER).
5. THERMOSTATS & LIQUID LINE SOLENOID VALVES: OPTIONAL.
6. DRAIN: 1 1/2 INCH PVC.
7. SPECIFICATIONS SUBJECT TO CHANGE WITHOUT NOTICE.

AUTHORIZATION (PRINT):	DATE:	 börgeren systems		SCALE: 1:32	DRAWN BY: D HUNT
SIGNATURE:				DATE: 9-24-08	CHECKED BY:
		12FT SALAD BAR			DRAWING NUMBER
		DATE	REV	DN	INCH
		REVISION	TOL:	P5493A	