

DL100 4' REMOTE GOURMET SANDWICH SPECIFICATIONS:

REFRIGERATION
 LOAD: 1000 BTU/hr
 SUCTION TEMP: 20° F
 LIQUID LINE: 3/8IN ODS
 SUCTION LINE: 5/8IN ODS

ELECTRICAL: 115VAC, 60HZ, 1PH.
 EVAP. FANS: .54A
 TOTAL: .54A
 MCA: 15.0A

NOTES:

1. OPTIONS NOT SHOWN ON DRAWING SHOULD BE LISTED IN WRITTEN PROPOSAL AND LISTED ON PURCHASE ORDER.
2. ELEC. CONNECTION: 115V/230V, 4x4 SUPPLY BOX AS NEEDED.
3. EXPANSION VALVES: SPORLAN "Q" SERIES STANDARD UNLESS OTHERWISE SPECIFIED.
4. DEFROST CONTROL: REMOTE CASES (N/A, DIGITAL CASE CONTROLLERS AVAILABLE), OPTIONAL CONDENSING UNIT (DIGITAL CASE CONTROLLER).
5. THERMOSTATS & LIQUID LINE SOLENOID VALVES: OPTIONAL.
6. DRAIN: 1 1/2 INCH PVC.
7. SPECIFICATIONS SUBJECT TO CHANGE WITHOUT NOTICE.

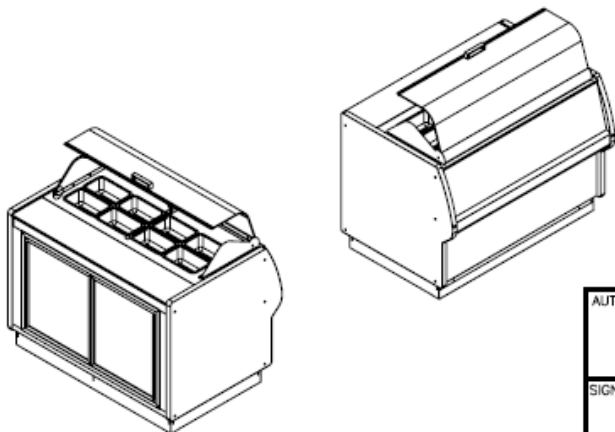

AUTHORIZATION (PRINT):		DATE:		 börgeren systems	
SIGNATURE:					
				DATE: 8-14-06	CHECKED BY:
				4' GOURMET SANDWICH BG4GS	
DATE	REV	BY	INCH	DRAWING NUMBER	
				P4795A	