

P=POWER SUPPLY BOX
 R=REFRIGERATION STUBS
 D=DRAIN STUB

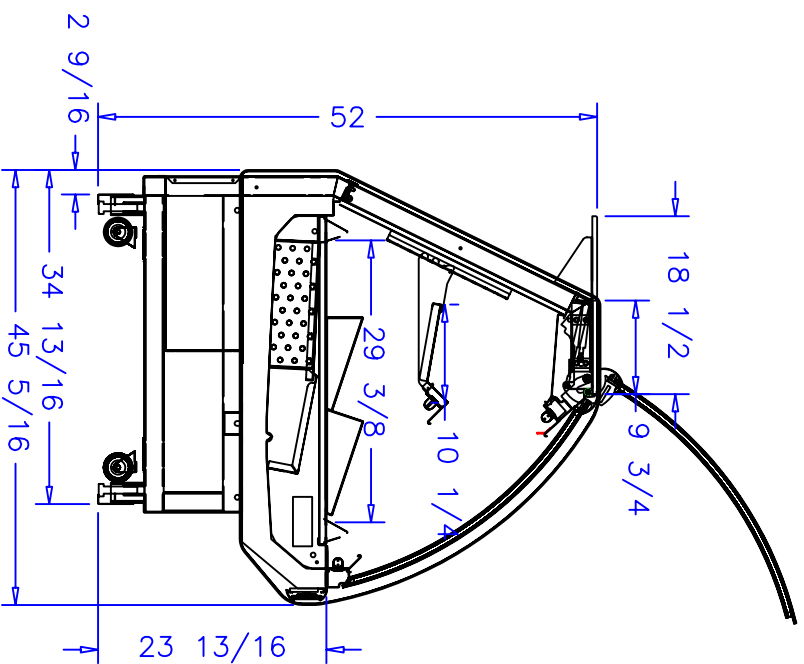

DL1100 10' REMOTE DELI
 SPECIFICATIONS:
 REFRIGERATION
 LOAD: 4500 BTU/hr
 SUCTION TEMP: 20° F
 LIQUID LINE: 3/8IN ODS
 SUCTION LINE: 5/8IN ODS
 ELECTRICAL 115VAC, 60HZ, 1PH.
 EVAP. FANS: 2.08A
 LIGHT BALLAST: 1.0A
 TOTAL: 3.08A

NOTE, SEPARATE ISOLATED OUTLET PROVIDED

börger systems

SCALE: 1:20		DATE: 10-21-03		DRAWN BY: DWT	
DATE		REV		DIM: INCH	
REVISION		TOL: ±1/32		DRAWING NUMBER	
				P4254A	
				10' REMOTE DELI	
				DL1100 SERIES	
				DL1100 - 10D	