

CASE SPECIFICATIONS:

REFRIGERATION LOAD: 3,570 BTU/hr
 SUCTION TEMP: 20° F
 LIQUID LINE: 3/8IN ODS
 SUCTION LINE: 5/8IN ODS

ELECTRICAL 115V, 60HZ, 1PH.
 EVAP. FANS: 0.72A
 LIGHT BALLASTS: 7.2A
 CONDENSATE PUMP: 1.0A
 EVAP. PAN: 3.0A
 TOTAL: 11.92A

ELECTRICAL 230V, 60HZ, 1PH.
 1HP COND. UNIT: 8.7A
 TOTAL: 8.7A

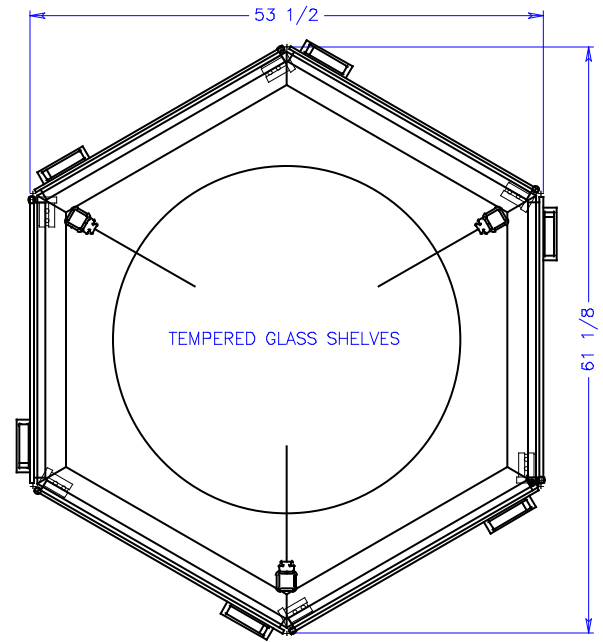

NOTES:

1. OPTIONS NOT SHOWN ON DRAWING SHOULD BE STATED IN WRITTEN PROPOSAL AND LISTED ON PURCHASE ORDER.
2. ELEC. CONNECTION: 115V/230V, 4X4 SUPPLY BOX AS NEEDED.
3. EXPANSION VALVES: SPORLAN "Q" SERIES STANDARD UNLESS OTHERWISE SPECIFIED.
4. DEFROST CONTROL: REMOTE CASES (N/A, DIGITAL CASE CONTROLLERS AVAILABLE), OPTIONAL CONDENSING UNIT (DIGITAL CASE CONTROLLER).
5. THERMOSTATS & LIQUID LINE SOLENOID VALVES: OPTIONAL.
6. DRAIN: 1 INCH NATIONAL PIPE STRAIGHT THREAD.
7. SPECIFICATIONS SUBJECT TO CHANGE WITHOUT NOTICE.

		börger systems	
	SCALE: 1:12		DRAWN BY: J. MAUK
	DATE: 12-9-94		CHECKED BY:
2-22-00	DRH	HEXAGON	
8-3-98	DRH		
DATE:	REV.	DIM: INCHES	DRAWING NUMBER
REVISION		TOL: ±1/4	P1837B